



PromArm

2020



CATALOG
Butterfly Valves

PromArm was founded in 2001 and for many years successfully deals with complex supplies industrial valves for various industries. We have accumulated vast experience, developed a production base, and formed a professional team for these years.

Based on the modern market needs, in 2009, we have launched our own production of butterfly valves, and in 2013, mastered production of knife gate valves. This catalog provides the main types of butterfly valves, produced under the PA brand.

In the manufacture of valves, we rely on the highest quality, which is achieved due to:

- a modern design of butterfly valves, providing reliable operation and "A" tightness class;
- incoming inspection of all materials and components;
- optimal organization of production and quality control at all stages;

All products are tested for leaks before shipment.



Our valves are used in various industries - oil and gas, chemical, power, utilities, mechanical engineering, metallurgy, shipbuilding.

They are used as shut-off and control valves for a wide variety of working media: water, steam, gas, oil products, aggressive and abrasive media.

Upon requests of our customers, we are ready to equip our valves with gearboxes, electric, pneumatic actuators, control columns, mating flanges, fittings and any other additional accessories. PromArm provides maintenance and warranty service for all products supplied.

In case of any special requirements to the proposed knife gate valves, our company is ready to consider any of your wishes and manufacture products with the required parameters.

Contacts

Address: Baumana St, 101 V, 440052, Penza, Russia

Tel/fax +7 (841-2) 35-07-97 (multichannel)

info@promarm.ru

www.promarm.ru

Contents

Series PA200	5
Series PA300	11
Series PA400	18
Series PA600	24
Series PA700	29
Series PA900	35
Information table	44
References	45
Certificates	46
Contacts	47

Classification of butterfly valves series PA

Series PA200



Lined butterfly valves

Series PA300



Butterfly valves with a symmetrical disk

Series PA400



Butterfly valves with double offset

Series PA600



Butterfly valves with a symmetrical disk

Series PA700



Butterfly valves with double offset

Series PA900



Butterfly valves with triple offset

PA	1	2	3	DN	PN	-	4	5
----	---	---	---	----	----	---	---	---

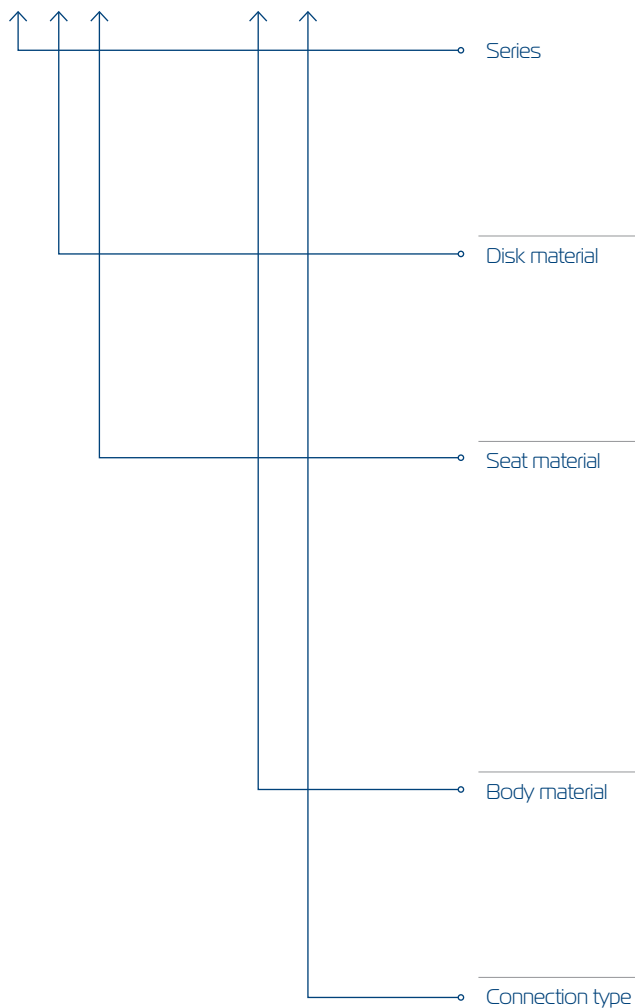

2	PA200 – lined butterfly valves
3	PA300 – butterfly valves with a symmetrical disk
4	PA400 – butterfly valves with double offset
6	PA600 – butterfly valves with a symmetrical disk
7	PA700 – butterfly valves with double offset
9	PA900 – butterfly valves with triple offset
1	Bronze
2	Carbon steel
3	Ductile cast iron
4	Stainless steel
5	Stainless steel with molybdenum
6	Construction alloyed steel
1	NBR
2	EPDM
3	VITON
4	PTFE
5	PTFE+SS (fire safe)
6	SS304+graphite – corrosion-resistant steel + graphite
7	SS304,SS316 – corrosion-resistant steel (metal-on-metal)
8	SS304,SS316+graphite – corrosion-resistant steel + graphite, bidirectional
9	Silicon
01	Ductile cast iron
02	Carbon steel
03	Cast iron
04	Stainless steel
05	Stainless steel with molybdenum
06	Construction alloyed steel
-	Wafer type with smooth lugs
P	Wafer type with threaded lugs
Φ	Flange type acc. to GOST 12815-80
Π	Welded

LINED BUTTERFLY VALVES SERIES PA200



Butterfly valves series PA200 with a lined disk and body are designed for industries with increased resistance to corrosive environments, where the temperature of the working medium does not exceed +200 °C. Valves can also be used in non-aggressive environments.

100% -PTFE coating of the flow-through part of the body and the disk completely eliminates the working medium contact with the materials of main parts.

Connection type is flanged and wafer. Valves series PA200 can be used as shut-off and control valves.

Upon customer's request, valves of this series can be equipped with electric, pneumatic actuators of various manufacturers, both in general industrial and in explosionproof design. And also with a set of mating flanges and fasteners.

Manufacture and supply:	Acc. to TU 3700-001-55604618-2013
Type of construction:	Butterfly valves with lined disk and flow-through part
Nominal diameter:	DN 40 – DN 1200 mm
Nominal pressure:	PN 10, 16 kgf/cm ²
Temperature of working medium:	Up to +200°C
Operation:	<ul style="list-style-type: none"> – handle DN 40-200 mm – gearbox DN 40-1200 mm – electric or pneumatic actuator DN 40-1200 mm
Leakage class:	«A» acc. to GOST 9544-2015
Main working mediums:	Water, concentrated acids, alkalis, oxidizing agents, organic solvents, chemicals nonaggressive to body coating and valve disk material
Connection type:	<ul style="list-style-type: none"> – wafer type with smooth lugs; – wafer type with threaded lugs; – flanged. Connecting flanges according to GOST 33259-2015
Installation position:	Any, except the position "electric actuator down" for valves with electric actuator
Flow direction of the working mediums:	Any
Climatic version:	Y, TM, TB acc. to GOST 15150-69
Top flange:	Acc. to ISO 5211

Classification of butterfly valves series PA200

Valve design:

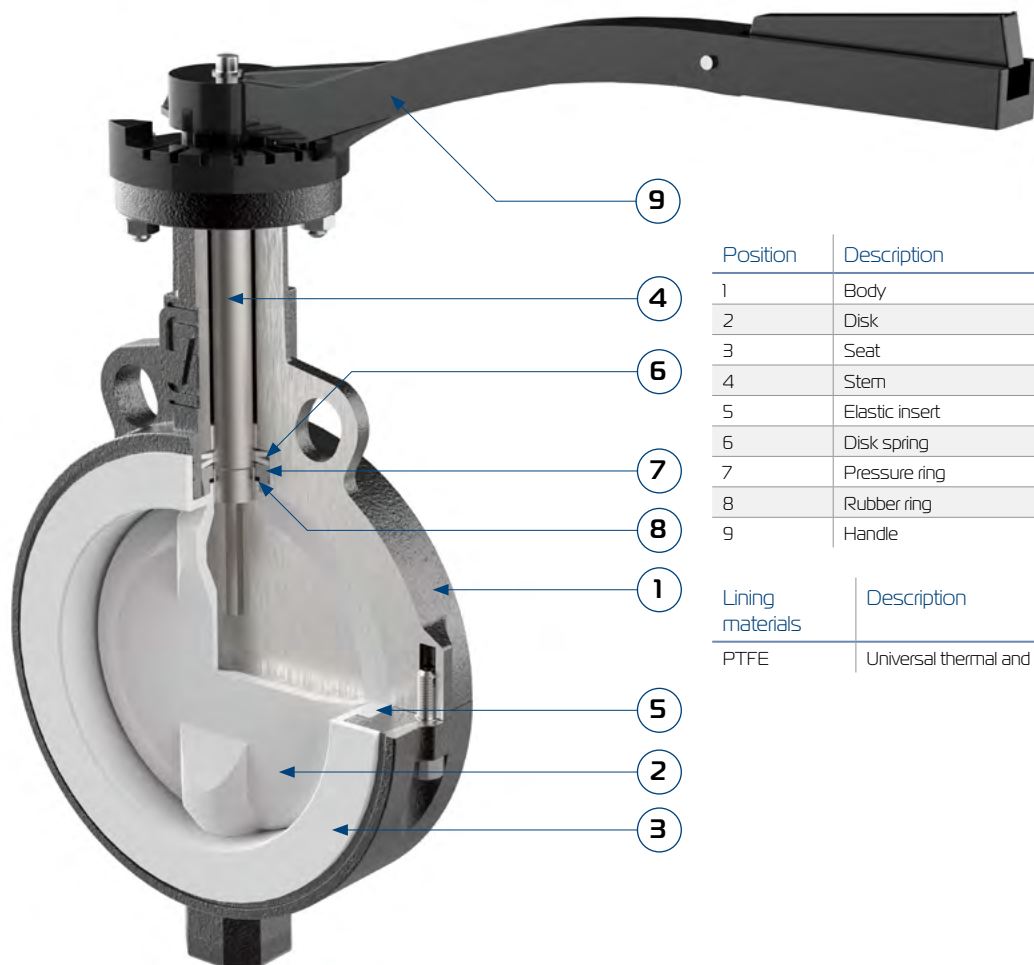

Position	Description
1	Body
2	Disk
3	Seat
4	Stem
5	Elastic insert
6	Disk spring
7	Pressure ring
8	Rubber ring
9	Handle

Lining materials	Description
PTFE	Universal thermal and chemical resistance

Designation

PA 1 2 3 DN PN - 4 5

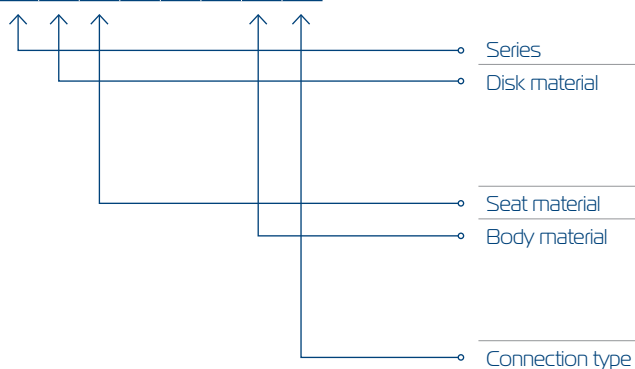

Series	2	PA200 – lined butterfly valves
Disk material	2	Carbon steel
	3	Ductile cast iron
	4	Stainless steel
	5	Stainless steel with molybdenum
	4	PTFE
Seat material	01	Ductile cast iron
	02	Carbon steel
	04	Stainless steel
	05	Stainless steel with molybdenum
	Body material	-
P		Wafer type with threaded lugs
Φ		Flanged

Example:

PA224.100.10-02

- series PA200,
- disk of carbon steel,
- lining - PTFE,
- DN100 mm, PN10 kgf/cm²,
- body of carbon steel,
- wafer connection

When choosing the material of the disk and seat for real working parameters, it is recommended to consult with the employees of PromArm Company.

Main overall and connection dimensions Wafer type connection with smooth lugs

With handle

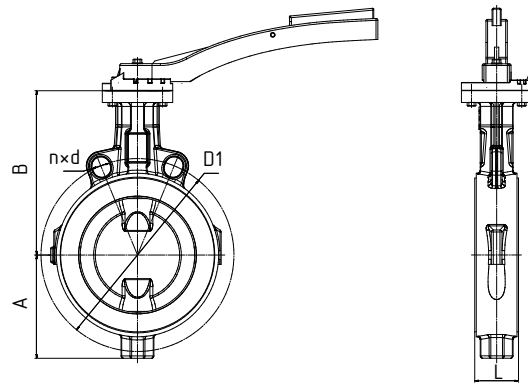

DN	Dimensions, mm						Weight with handle, kg	
	A	B	L	D1		n*d		
				PN10	PN16	PN10		PN16
40	50	100	33	110	110	Four universal holes for PN10, 16		3
50	65	135	43	125	125			3,5
65	74	150	46	145	145			3,8
80	84	156	46	160	160			5
100	100	180	52	180	180			7
125	110	195	56	210	210			9
150	132	210	56	240	240	11		

With gearbox

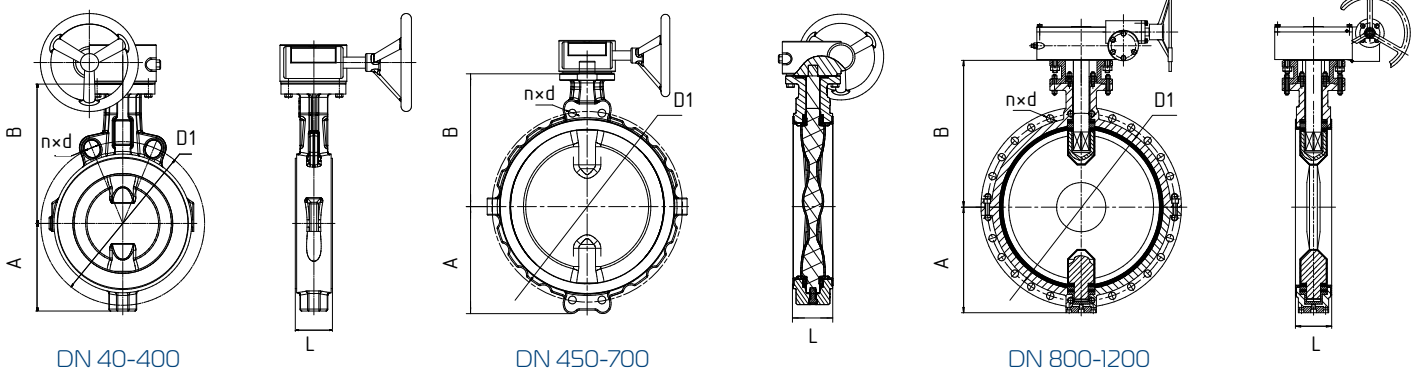

DN	Dimensions, mm						Weight with gearbox, kg	
	A	B	L	D1		n*d		
				PN10	PN16	PN10		PN16
40	50	100	33	110	110	Two universal holes for PN10, 16		4,2
50	65	135	43	125	125			4,7
65	74	150	46	145	145			5
80	84	156	46	160	160			6,2
100	100	180	52	180	180			8,2
125	110	195	56	210	210			11
150	132	210	56	240	240	13		
200	164	237	60	295	295	19		
250	185	274	68	350	355	29		
300	222	300	78	400	410	45		
350	261	325	78	460	470	Four universal holes for PN10, 16		55
400	285	342	102	515	525			88
450	305	403	114	565	585	20x27	20x30	115
500	338	446	127	620	650	20x27	20x33	150
600	398	509	154	725	770	20x30	20x36	230
700	520	553	165	840	840	24x30	24x36	293
800	600	830	190	950	950	24x33	24x39	490
1000	750	980	216	1160	1170	28x33	28x39	871
1200	870	1150	254	1380		32x39		1160

Wafer type with threaded lugs

With handle

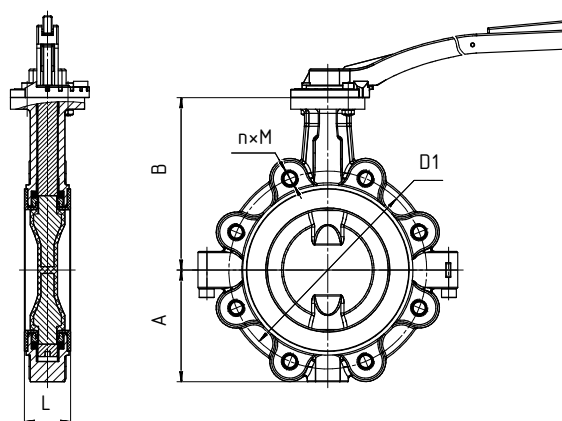

DN	Dimensions, mm							Weight with handle, kg
	A	B	L	D1		n*M		
				PN10	PN16	PN10	PN16	
40	50	100	33	110	110	4xM16	4xM16	4
50	63	110	43	125	125	4xM16	4xM16	4,5
65	72	125	46	145	145	4xM16	4xM16	4,8
80	80	136	46	160	160	4xM16	4xM16	6
100	111	151	52	180	180	8xM16	8xM16	10
125	124	170	56	210	210	8xM16	8xM16	12
150	138	190	56	240	240	8xM20	8xM20	15

With gearbox

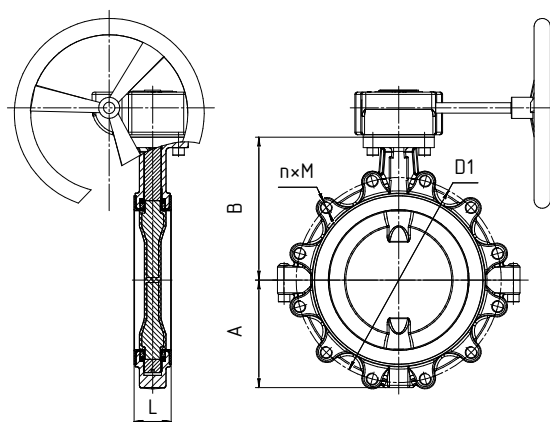

DN	Dimensions, mm							Weight with gearbox, kg
	A	B	L	D1		n*M		
				PN10	PN16	PN10	PN16	
40	50	100	33	110	110	4xM16	4xM16	5,2
50	63	110	43	125	125	4xM16	4xM16	5,7
65	72	125	46	145	145	4xM16	4xM16	6
80	80	136	46	160	160	4xM16	4xM16	7,2
100	111	151	52	180	180	8xM16	8xM16	11,2
125	124	170	56	210	210	8xM16	8xM16	14
150	138	190	56	240	240	8xM20	8xM20	17
200	171	222	60	295	295	8xM20	12xM20	27
250	209	270	68	350	355	12xM20	12xM24	38
300	230	290	78	400	410	12xM20	12xM24	60
350	261	325	78	460	470	16xM20	16xM24	78
400	285	342	102	515	525	16xM24	16xM27	115
450	305	375	114	565	585	20xM24	20xM27	159
500	338	415	127	620	650	20xM24	20xM30	204
600	397	479	154	725	770	20xM27	20xM33	309

Wafer type

With handle

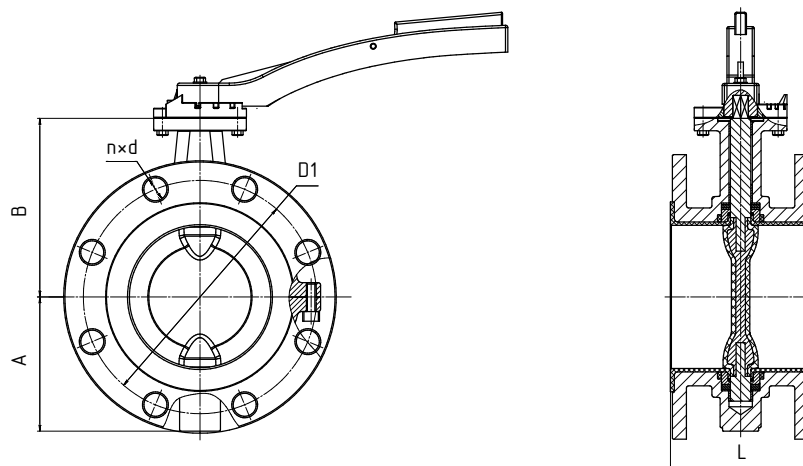

DN	Dimensions, mm							Weight with handle, kg
	A	B	L	D1		n*d		
				PN10	PN16	PN10	PN16	
40	50	100	106	110	110	4x18	4x18	10
50	63	110	108	125	125	4x18	4x18	12
65	72	125	112	145	145	4x18	4x18	13
80	80	136	114	160	160	4x18	4x18	14
100	111	151	127	180	180	8x18	8x18	17
125	124	170	140	210	210	8x18	8x18	19
150	138	190	140	240	240	8x22	8x22	24

With gearbox

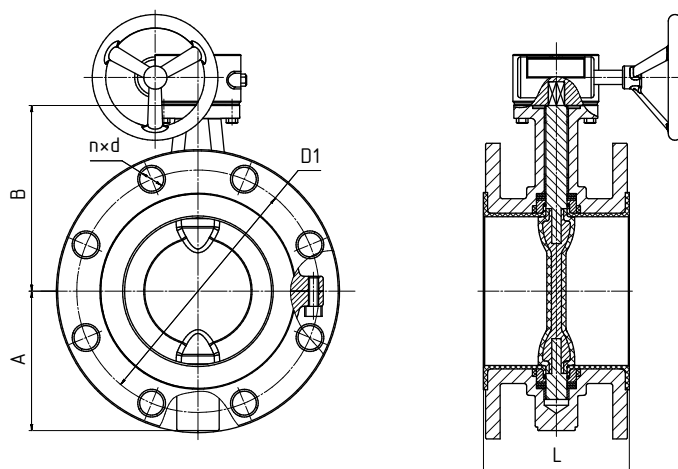

DN	Dimensions, mm							Weight with gearbox, kg
	A	B	L	D1		n*d		
				PN10	PN16	PN10	PN16	
40	50	100	106	110	110	4x18	4x18	12
50	63	110	108	125	125	4x18	4x18	14
65	72	125	112	145	145	4x18	4x18	15
80	80	136	114	160	160	4x18	4x18	16
100	111	151	127	180	180	8x18	8x18	19
125	124	170	140	210	210	8x18	8x18	22
150	138	190	140	240	240	8x22	8x22	27
200	171	222	152	295	295	8x22	12x22	35
250	209	270	165	350	355	12x22	12x26	56
300	230	290	178	400	410	12x22	12x26	91
350	261	325	190	460	470	16x22	16x26	137
400	285	342	216	515	525	16x26	16x30	189
450	315	406	222	565	585	20x26	20x30	210
500	352	448	229	620	650	20x26	20x33	292
600	441	518	267	725	770	20x30	20x39	363

Top flange's dimensions and torque for choosing actuator

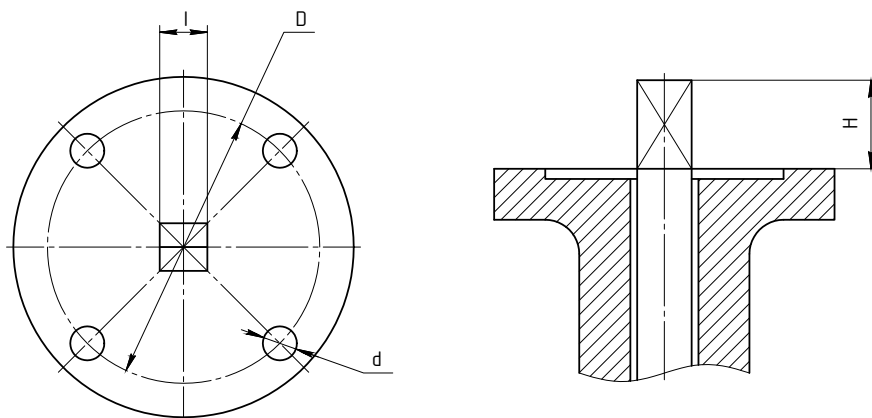

DN	Top flange acc. to ISO	Dimensions, mm				Torque, H*m	
		D	d	l	H	PN10	PN16
40	F05	50	7	11	13	30	45
50	F05	50	7	11	13	35	50
65	F05	50	7	11	13	40	55
80	F05	50	7	11	13	54	75
100	F07	70	10	14	16	80	115
125	F07	70	10	17	16	105	150
150	F07	70	10	17	16	150	210
200	F10	102	12	22	24	265	370
250	F10	102	12	22	24	430	600
300	F12	125	14	27	29	660	930
350	F12	125	14	27	29	905	
400	F14	140	18	27	38	1240	
450	F14	140	18	36	38	1720	
500	F16	165	22	36	38	2150	
600	F16	165	22	46	48	3400	
700	F25	254	18	55	48	5010	

Flow capacity of valves Kv, m³/h

DN	40	50	65	80	100	125	150	200	250	300	350	400	450	500	600
Kv	60	121	272	476	857	1382	2282	4037	4821	7054	10050	13464	17218	21745	29802

The dimensions and torque is approximate, for correct selection of electrical and pneumatic actuators it is recommended to consult with the representatives of PromArm company.

Reliability parameters of butterfly valves

DN	40-100	125,150	200-300	350,400	450-600
Mean life, cycles, not less	5000	4000	3600	3000	2000
Warranty life, cycles, not less than	1800	1500	1400	1200	800

Average life and warranty life of the sealing materials identified when testing valves with water according to GOST 2874-82

When operating valves for working mediums other than water, the reliability parameters are determined by the specific mediums, depending on its parameters.

Warranty

The warranty period is 18 months from the date of putting into operation, but not more than 24 months from the date of sale under condition of observance by the consumer of rules of transportation, installation and operation. Conservation period - 3 years.

Average service life of body parts is not less than 30 years.

Average life removable parts and components – at least 5 years.

BUTTERFLY VALVES SERIES PA300



Butterfly valves series series PA300 is a butterfly valves with a symmetrical disk, and the elastomer seat. By default, the connection type is wafer, but may also manufacture with flanges or with threaded lugs. When installed butterfly valves do not require additional seals, elastomer seat covers body from both sides and the contraction of the stopper between the flanges provides tightness of the connection. Seats are available in removable and in-situ option (by means of curing) and have a bi-directional seal without leaks. The design feature of butterfly valves series PA300 in that the working medium is not in contact with the valve body. Therefore, the working characteristics of the valve depend on the materials of the seat and disk. Butterfly valves series PA300 are used in a various industries: heating, water supply, ventilation, conditioning, gas supply, etc.

Manufacture and supply:	Acc. to TU 3700-001-55604618-2013
Type of construction:	Butterfly valve with symmetric disk, seat material - elastomer
Nominal diameter:	DN 25 – DN 1200 mm
Nominal pressure:	– PN 6, 10, 16, 25 kgf/ cm ²
Temperature of working medium:	Up to +180°C depending on the seat material
Operation:	– handle DN 25-200 mm – gearbox DN 25-1200 mm – electric or pneumatic actuator DN 25-1200 mm
Leakage class:	«A» acc. to GOST 9544-2015
Main working mediums:	Water, air, natural gas and gaseous products, ammonia gas, petroleum products, hydrocarbons, acids, alkalis, alcohols, sea water
Connection type:	– wafer type with smooth lugs; – wafer type with threaded lugs; – flange type. Connecting flanges according to GOST 33259-2015
Installation position:	Any, except the position "electric actuator down" for valves with electric actuator
Flow direction of the working mediums:	Any
Flow rate of the working medium:	Up to 80 m/s for gases, up to 5 m/s for liquids
Climatic version:	V, VXA, T, TM, TB acc. to GOST 15150-69
Flow characteristic of valves:	With opening angles from 20° to 70° valves can be used for throttling the flow of working medium
Top flange:	Acc. to ISO 5211

PromArm LLC reserves the right to make changes to the design not affecting functional characteristics of the equipment.

Classification of butterfly valves series PA300

Valve design:

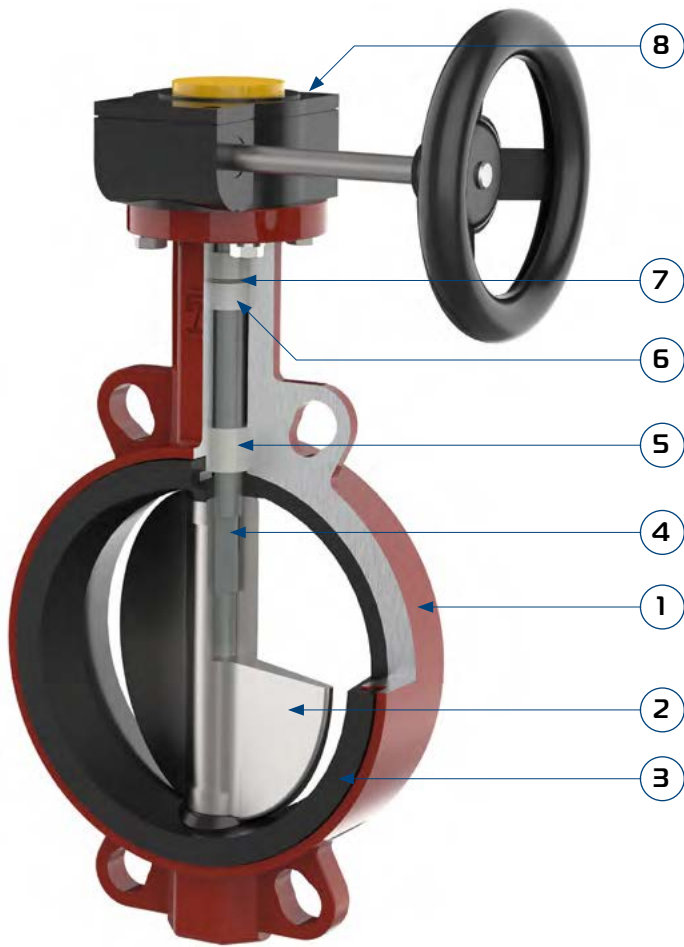

Position	Description
1	Body
2	Disk
3	Seat
4	Stem
5,6	Bushing
7	O-ring
8	Worm gear

Seat materials	Description
NBR	- resistance to oils, lubricants, fuels, natural gas; - not resistant to alkali and acid environments, water vapor
EPDM	- resistance to water, alkalis, acids, abrasive materials, air; - not resistant to fuels and lubricants, fats
Viton	- resistance to oils, gasoline, diz.fuel, diluted acids and alkalis of medium concentration; - not resistant to ketones, hot water, steam
PTFE	- universal thermal and chemical resistance

Designation

ПА 1 2 3 DN PN - 4

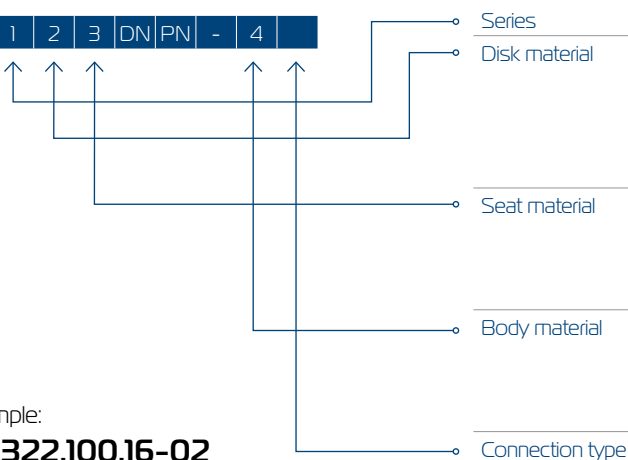

Series	3	PA300 – butterfly valves with a symmetrical disk
Disk material	1	Bronze
	2	Carbon steel
	3	Ductile cast iron
	4	Stainless steel
	5	Stainless steel with molybdenum
Seat material	1	NBR
	2	EPDM
	3	VITON
	4	PTFE
Body material	01	Ductile cast iron
	02	Carbon steel
	03	Cast Iron
	04	Stainless steel
Connection type	-	Wafer type with smooth lugs
	P	Wafer type with threaded lugs
	Φ	Flange type acc. to GOST 12815-80

Example:

ПА322.100.16-02

- series PA300,
- disk of carbon steel,
- seat - EPDM,
- DN100 mm, PN16 kgf/cm²,
- body of carbon steel,
- wafer type

When choosing the material of the disk and seat for real working parameters, it is recommended to consult with the employees of PromArm Company.

Main overall and connection dimensions Wafer type connection with smooth lugs

DN 25-200 mm with handle

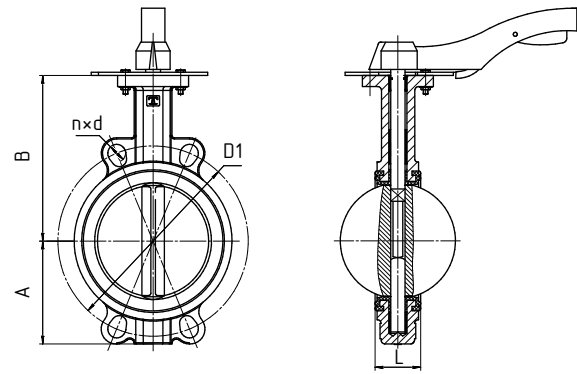

DN	Dimensions, mm						Weight with handle, kg	
	A	B	L	D1		n*d		
				PN10	PN16	PN10		PN16
25	53	120	26				1,6	
32/40	54	140	33	110	110	Four universal holes for PN10, 16	2,9	
50	60	140	43	125	125		3	
65	67	150	46	145	145		3,7	
80	87	158	46	160	160		4,2	
100	105	180	52	180	180		6	
125	118	190	56	210	210		6,5	
150	130	210	56	240	240		8	
200	166	235	60	295	295		15	

DN 25-400 mm with gearbox

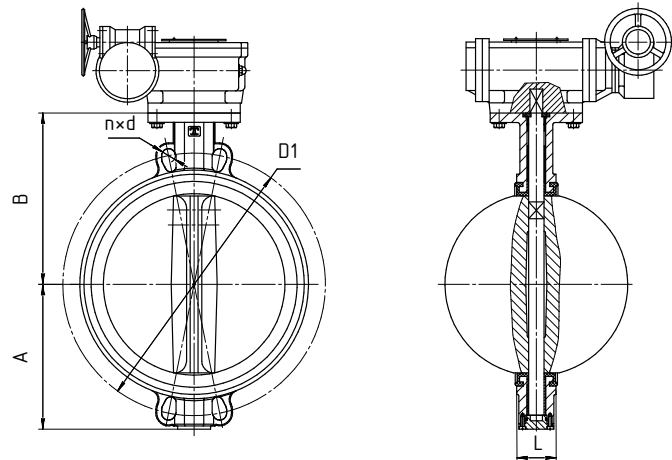

DN	Dimensions, mm						Weight with gearbox, kg	
	A	B	L	D1		n*d		
				PN10	PN16	PN10		PN16
25	53	120	26	85	85		2,6	
32/40	54	140	33	110	110	Four universal holes for PN10, 16	4	
50	60	140	43	125	125		4,2	
65	67	150	46	145	145		4,7	
80	87	158	46	160	160		5,2	
100	105	180	52	180	180		7	
125	118	190	56	210	210		7,5	
150	130	210	56	240	240		9	
200	166	235	60	295	295		18	
250	197	270	68	350	355		29	
300	230	310	78	400	410		34	
350	255	360	78	460	470		50	
400	291	380	102	515	525		85	
450	328	422	114	565	585		90	
500	387	460	127	620	650		123	
600	435	490	154	725	770		230	

Wafer type with smooth lugs

DN 700-1200 mm with gearbox

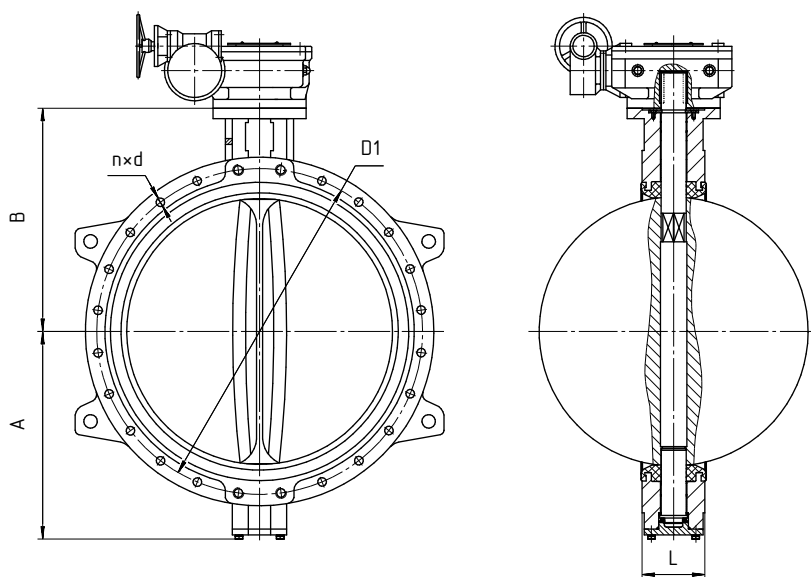

DN	Dimensions, mm							Weight with gearbox, kg
	A	B	L	D1		n*d		
				PN10	PN16	PN10	PN16	
700	512	635	165	840	840	24x30	24x39	366
800	600	674	190	950	950	24x33	24x39	470
900	656	720	203	1050	1050	28x33	28x39	552
1000	721	800	216	1160	1170	28x36	28x45	760
1200	864	941	254	1380	1390	32x39	32x52	1150

Wafer type with threaded lugs

DN 40-200 mm with handle

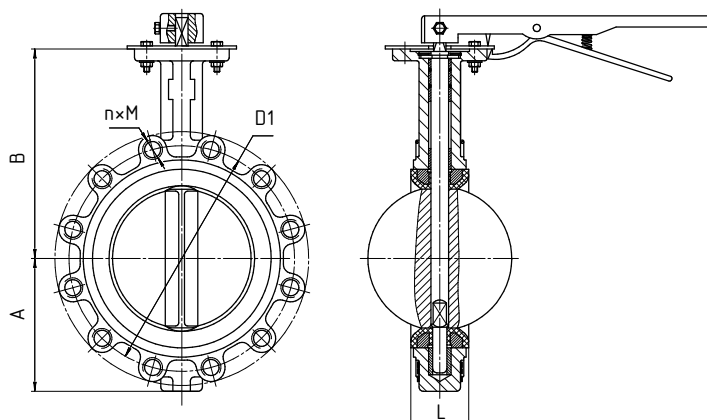

DN	Dimensions, mm							Weight with handle, kg
	A	B	L	D1		n*M		
				PN10	PN16	PN10	PN16	
32/40	54	140	33	110	110	4xM16	4xM16	3,5
50	60	140	43	125	125	4xM16	4xM16	3,8
65	67	150	46	145	145	4xM16	4xM16	4,5
80	87	158	46	160	160	4xM16	4xM16	5
100	105	180	52	180	180	8xM16	8xM16	8
125	118	190	56	210	210	8xM16	8xM16	9
150	130	210	56	240	240	8xM20	8xM20	11
200	166	235	60	295	295	8xM20	12xM20	19

DN 40-600 mm with gearbox

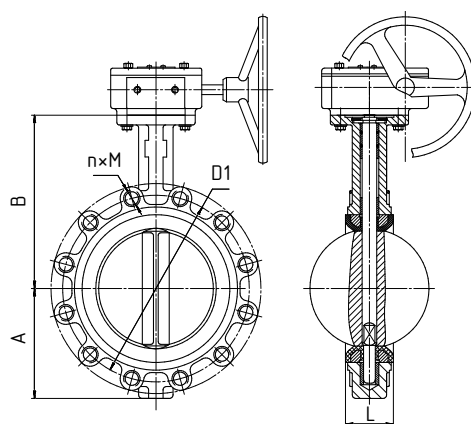

DN	Dimensions, mm							Weight with gearbox, kg
	A	B	L	D1		n*M		
				PN10	PN16	PN10	PN16	
40	54	140	33	110	110	4xM16	4xM16	4,7
50	60	140	43	125	125	4xM16	4xM16	5
65	67	150	46	145	145	4xM16	4xM16	5,7
80	87	158	46	160	160	4xM16	4xM16	6,2
100	105	180	52	180	180	8xM16	8xM16	9,2
125	118	190	56	210	210	8xM16	8xM16	11
150	130	210	56	240	240	8xM20	8xM20	13
200	166	235	60	295	295	8xM20	12xM20	22
250	197	270	68	350	350	12xM20	12xM24	42
300	230	310	78	400	410	12xM20	12xM24	51
350	255	360	78	460	470	16xM20	16xM24	67
400	291	380	102	515	525	16xM24	16xM27	105
450	328	422	114	565	585	20xM24	20xM27	133
500	387	460	127	620	650	20xM24	20xM30	180
600	435	490	154	725	770	20xM27	20xM33	270

Wafer type

DN 50-150 mm with handle

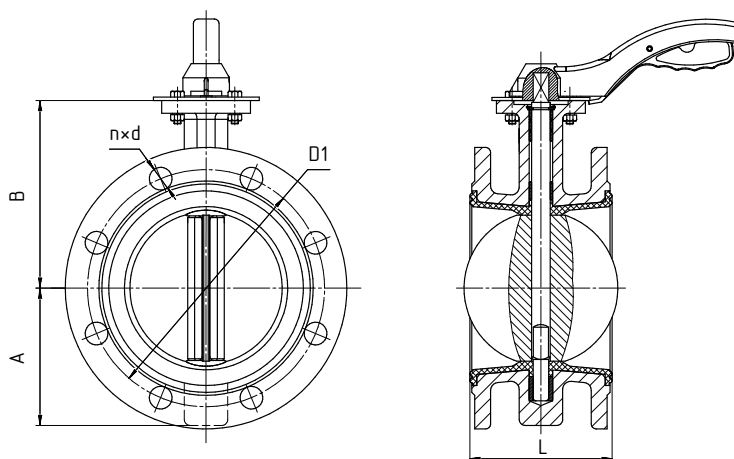

DN	Dimensions, mm							Weight with handle, kg	
	A	B	L	D1		n*d			
				PN10	PN16	PN10	PN16		
50	80	110	108	125	125	4x18	4x18	6	
65	80	134	112	145	145	4x18	4x18	8	
80	95	131	114	160	160	4x18	8x18	9	
100	114	155	127	180	180	8x18	8x18	12	
125	113	170	140	210	210	8x18	8x18	14	
150	139	190	140	240	240	8x23	8x23	18	

DN 50-1200 mm with gearbox

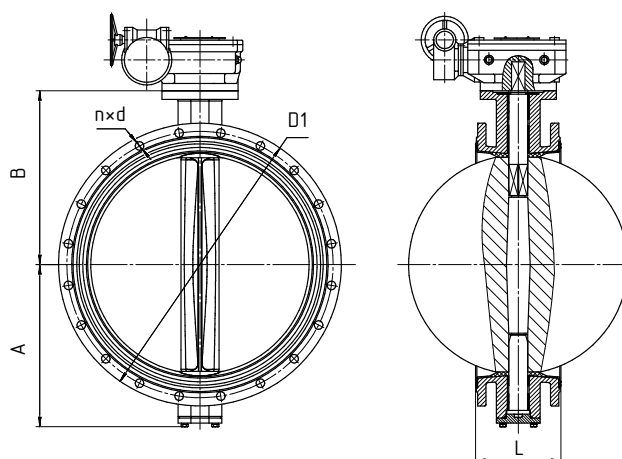

DN	Dimensions, mm							Weight with gearbox, kg	
	A	B	L	D1		n*d			
				PN10	PN16	PN10	PN16	PN10	PN16
50	80	110	108	125	125	4x18	4x18	10	10
65	80	134	112	145	145	4x18	4x18	12	12
80	95	131	114	160	160	4x18	8x18	13	13
100	114	155	127	180	180	8x18	8x18	17	17
125	113	170	140	210	210	8x18	8x18	19	19
150	139	190	140	240	240	8x23	8x23	24	24
200	175	210	152	295	295	8x22	8x22	31	31
250	203	245	165	350	355	8x22	12x22	51	51
300	223	280	178	400	410	12x22	12x26	64	64
350	254	310	190	460	470	12x22	12x26	70	79
400	306	340	216	515	525	16x22	16x26	120	135
450	315	406	222	565	585	16x26	16x30	142	158
500	378	430	229	620	650	20x26	20x33	160	225
600	440	500	267	725	770	20x30	20x36	260	330
700	510	560	292	840	910	24x30	24x39	360	375
800	560	620	318	950	1020	24x33	24x39	458	470
900	581	692	330	1050	1120	28x33	28x39	550	572
1000	645	735	410	1160	1255	28x36	28x42	792	812
1200	786	917	470	1380	1485	32x39	32x52	1045	1086

Top flange's dimensions and torque for choosing actuator

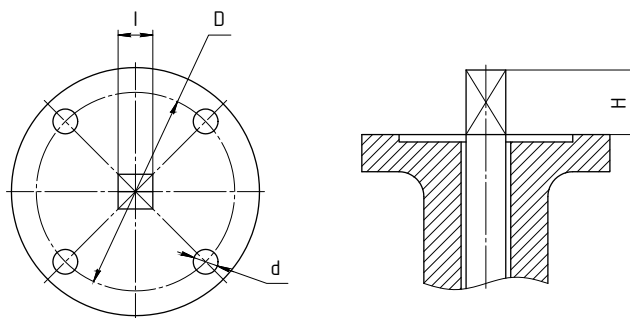

DN	Top flange acc. to ISO		D		Dimensions, mm			Torque, H*m	
	Iron	Steel	Iron	Steel	d	l	H	PN10	PN16
25	F04	F05	42	50	6	11	23	7	8
40	F05	F05	50	50	7	11	23	10	12
50	F05	F07	50	70	7	11	23	18	20
65	F05	F07	50	70	7	11	23	22	25
80	F05	F07	50	70	7	11	23	32	34
100	F07		70		10	11	30	53	57
125	F07		70		10	14	30	80	87
150	F07		70		10	14	30	130	140
200	F10		102		12	17	44	230	266
250	F10		102		12	22	40	390	404
300	F10		102		14	22	40	570	657
350	F12		125		14	22	40	700	810
400	F14		140		18	27	40	960	1105
450	F14		140		18	27	40	1280	1480
500	F14		140		18	27	40	1710	2100
600	F16		165		22	36	50	2680	3050
700	F25		254		18	46	50	4170	
800	F25		254		18	46	50	6200	
900	F25		254		18	55	60	6950	
1000	F25		254		18	55	60	11380	
1200	F30		298			60	70	16000	

The dimensions and torque is approximate, for correct selection of electrical and pneumatic actuators it is recommended to consult with the representatives of PromArm company.

Flow capacity of valves $K_v, m^3/h$

DN	40	50	65	80	100	125	150	200	250	300
K_v	65	138	214	309	561	1069	1853	3088	4750	7125
DN	350	400	450	500	600	700	800	900	1000	1200
K_v	8620	10416	15215	18959	24869	36200	44300	58000	80600	110500

Reliability parameters of butterfly valves

DN	40-100	125,150	200-300	350,400	450-600	700-900	1000,1200
Mean life, cycles, not less	5400	4400	4000	3400	2400	2000	1900
Warranty life, cycles, not less than	2000	1700	1600	1400	1000	800	650

Average life and warranty life of the sealing materials identified when testing valves with water according to GOST 2874-82

When operating valves for working mediums other than water, the reliability parameters are determined by the specific mediums, depending on its parameters.

Warranty

The warranty period is 18 months from the date of putting into operation, but not more than 24 months from the date of sale under condition of observance by the consumer of rules of transportation, installation and operation.

Conservation period - 3 years.

Average service life of body parts is not less than 30 years.

Average life removable parts and components – at least 5 years.

BUTTERFLY VALVES WITH DOUBLE OFFSET SERIES PA400



Valves of this series are designed for operation in harsher conditions than valves with a symmetrical disk (high temperatures, more cycles of actuation).

The disk is installed in the body with an offset relative to the axis of symmetry of the valve body and the pipeline axis. The seat and the disc have a conical profile, which together with a double offset allows the disk to come out of contact with the seat at minimum opening angles.

Connection type is wafer.

Valves of series PA400 are produced with sealing of 3 designs: with soft PTFE seat, in fire-safe design and with "metal-on-metal" seat.

Butterfly valves series PA400 are used in oil refining, chemical industry, metallurgy, technological pipelines of industrial enterprises, in energy industry, shipbuilding.

Manufacture and supply:	Acc. to TU 3700-001-55604618-2013
Type of construction:	Butterfly valves with double offset
Nominal diameter:	DN 50 – DN 1000 mm
Nominal pressure:	PN 10, 16, 25, 40 kgf/cm ²
Temperature of working medium:	Up to +450°C depending on the seat material
Operation:	– gearbox DN 50-1000 mm – electric or pneumatic actuator DN 50-1000 mm
Leakage class:	«A» acc. to GOST 9544-2015
Main working mediums:	Water, air, low pressure steam, oil, oil products, acids, alkalis, hydrocarbons, alcohols, seawater
Connection type:	– wafer type with smooth lugs; – wafer type with threaded lugs; Connecting flanges according to GOST 33259-2015
Installation position:	Any, except the position "electric actuator down" for valves with electric actuator
Flow direction of the working mediums:	Any
Climatic version:	V, YX\, T, TM, TB acc. to GOST 15150-69
Top flange:	Acc. to ISO 5211

PromArm LLC reserves the right to make changes to the design not affecting functional characteristics of the equipment.

Classification of butterfly valves series PA400

Valve design:

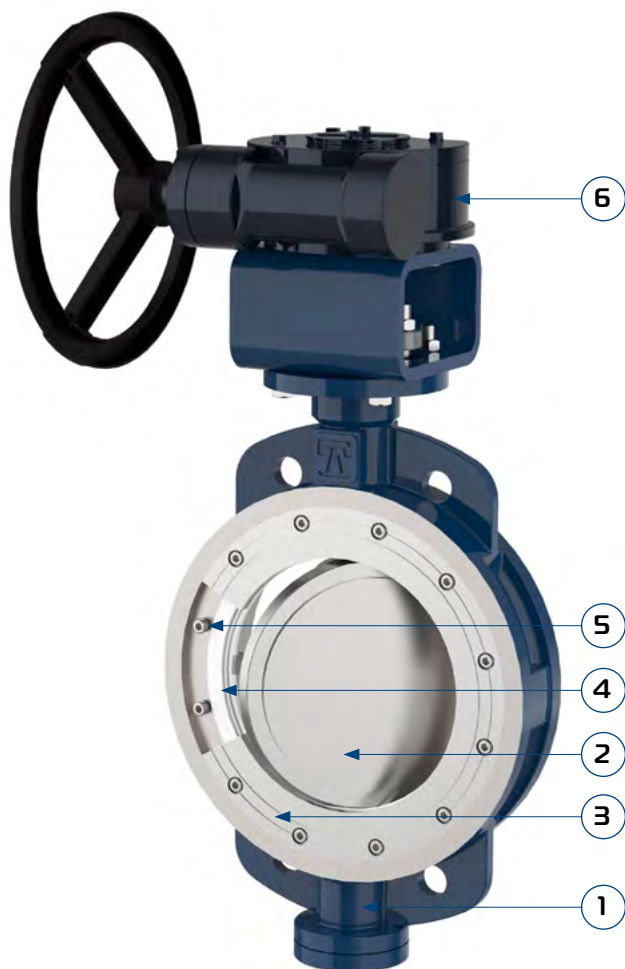

Position	Description
1	Body
2	Disk
3	Pressure ring
4	Seat
5	Bolt
6	Gearbox

Seat materials	Description
PTFE	Universal chemical and thermal stability
PTFE+SS	Fire-safe design
Steel SS304	Metal-on-metal sealing is used at high temperatures

Designation

PA	1	2	3	DN	PN	-	4	5	
									Series
									Disk material
									Seat material
									Body material
									Connection type
							4	PA400 – butterfly valves with double offset	
							2	Carbon steel	
							4	Stainless steel	
							5	Stainless steel with molybdenum	
							6	Construction alloyed steel	
							4	PTFE	
							5	PTFE+SS	
							7	SS304,SS316 – corrosion-resistant steel (metal-on-metal)	
							02	Carbon steel	
							04	Stainless steel	
							05	Stainless steel with molybdenum	
							06	Construction alloyed steel	
							-	Wafer type with smooth lugs	
							P	Wafer type with threaded lugs	

Example:

PA424.200.16-02P

- series PA400,
- disk of carbon steel,
- seat - PTFE,
- DN200 mm, PN16 kgf/cm²,
- body of carbon steel,
- wafer type with threaded lugs;

When choosing the material of the disk and seat for real working parameters, it is recommended to consult with the employees of PromArm Company. The above temperatures are maximum for this type of elastomer in a static condition.

Sealing diagram in butterfly valves with double offset

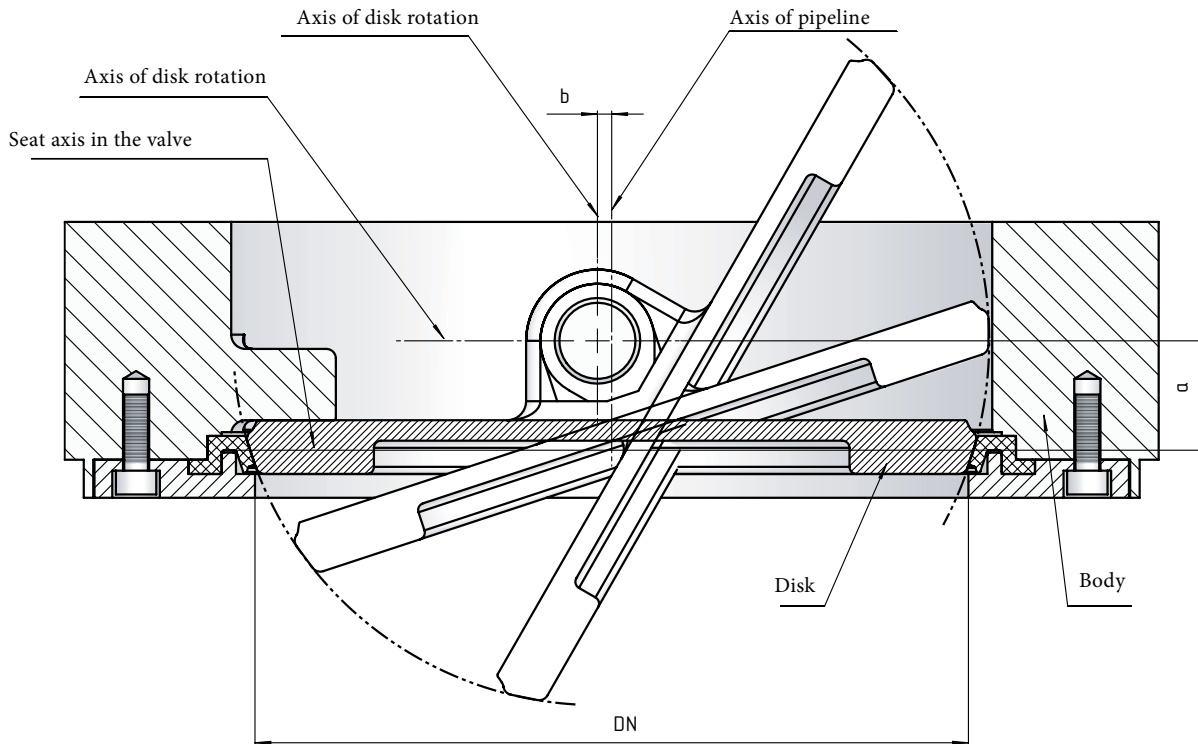

This figure shows the design of butterfly valves with double offset: offset "a" is the offset of the disk axis of rotation relative to the seat axis in the valve; offset "b" is the offset of the disk axis of rotation from the pipeline axis. This design reduces friction in the points of contact between the disk and the seat, which increases reliability and durability of these valves, reduces the torque to control the valve.

Seat types

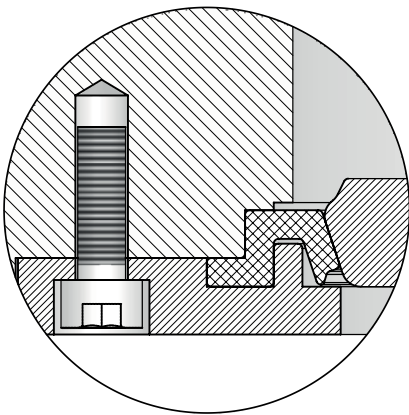

Soft PTFE

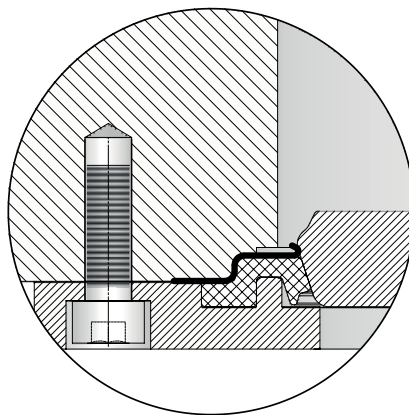

Fire-safe PTFE+metal

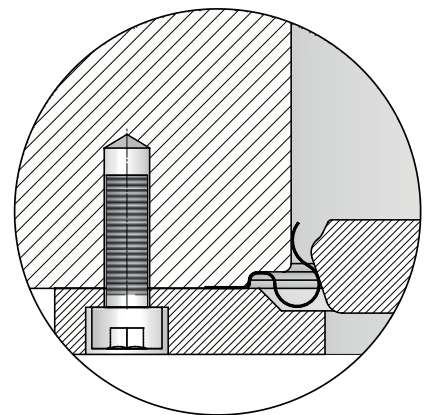

Metal-on-metal

Main overall and connection dimensions Wafer type connection with smooth lugs

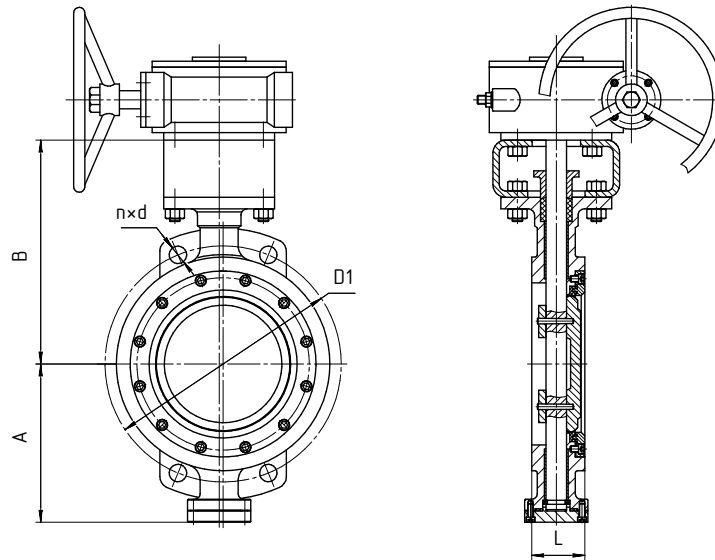

DN	PN10						PN16					
	Dimensions, mm					Weight with gearbox, kg	Dimensions, mm					Weight with gearbox, kg
	A	B	L	D1	n*d		A	B	L	D1	n*d	
50	65	175	43	125	4x18	9	80	175	43	125	4x18	9
65	75	190	46	145	4x18	10	90	190	46	145	4x18	10
80	105	195	49	160	4x18	11	105	195	49	160	4x18	11
100	117	215	52	180	8x18	14	117	215	52	180	8x18	14
125	135	250	56	210	8x18	22	135	250	56	210	8x18	22
150	176	270	61	240	8x22	25	176	270	61	240	8x22	25
200	202	320	64	295	8x22	38	202	320	64	295	12x22	38
250	235	355	71	350	12x22	53	235	355	71	355	12x26	53
300	265	385	82	400	12x22	63	265	385	82	410	12x26	63
350	305	415	92	460	16x22	94	305	415	92	470	16x26	94
400	335	470	102	515	16x26	140	335	470	102	525	16x30	140
500	405	535	127	620	20x26	190	405	535	127	650	20x33	190
600	450	610	154	725	20x30	290	450	610	154	770	20x39	290
700	520	680	165	840	24x30	430	520	680	165	840	24x39	430
800	590	750	190	950	24x33	535	590	750	190	950	24x39	535
900	650	800	203	1050	28x33	708	650	800	203	1050	28x39	708
1000	720	920	216	1160	28x33	1090	720	920	216	1170	28x45	1090

DN	PN25						PN40					
	Dimensions, mm					Weight with gearbox, kg	Dimensions, mm					Weight with gearbox, kg
	A	B	L	D1	n*d		A	B	L	D1	n*d	
50	65	175	43	125	4x18	9	80	175	43	125	4x18	11
65	75	190	46	145	8x18	10	90	190	46	145	8x18	12
80	90	195	49	160	8x18	11	105	195	64	160	8x18	13
100	117	215	52	190	8x22	14	117	220	64	190	8x22	17
125	135	250	56	220	8x26	22	155	260	70	220	8x26	27
150	176	270	61	250	8x26	25	175	320	76	250	8x26	30
200	185	320	64	310	12x26	38	220	330	89	320	12x30	46
250	215	360	71	370	12x30	53	250	370	114	385	12x33	64
300	250	395	82	430	16x30	63	300	435	114	450	16x33	76
350	283	455	92	490	16x33	94	330	480	127	510	16x33	113
400	325	480	102	550	16x33	140	340	535	140	585	12x39	168
500	375	580	127	660	20x39	210	415	610	152	670	20x45	252
600	430	640	154	770	20x39	315	480	630	178	795	20x52	378
700	540	720	165	875	24x45	461	550	730	229	900	24x52	553
800	710	820	190	990	24x45	595	620	810	241	1030	24x56	714
900	650	800	203	1090	28x52	752						
1000	720	940	216	1210	28x56	1270						

Wafer type with threaded lugs

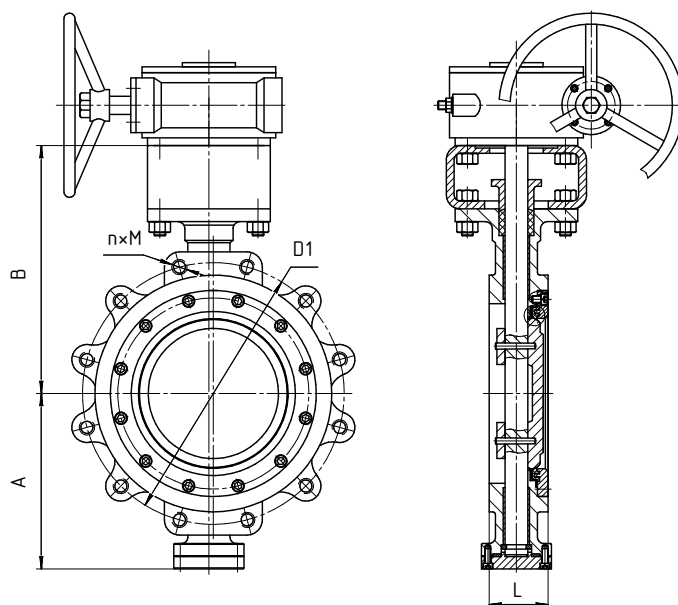

DN	PN10						PN16					
	Dimensions, mm					Weight with gearbox, kg	Dimensions, mm					Weight with gearbox, kg
	A	B	L	D1	n*M		A	B	L	D1	n*M	
50	65	175	43	125	4xM16	16	80	175	43	125	4xM16	16
65	75	190	46	145	4xM16	17	90	190	46	145	4xM16	17
80	90	195	49	160	8xM16	18	105	195	49	160	8xM16	18
100	117	215	52	190	8xM16	21	117	215	52	180	8xM16	21
125	135	250	56	220	8xM16	34	135	250	56	210	8xM16	34
150	176	270	61	250	8xM20	43	176	270	61	240	8xM20	43
200	185	320	64	310	12xM20	58	202	320	64	295	12xM20	58
250	215	360	71	370	12xM24	72	235	355	71	355	12xM24	72
300	250	395	82	430	12xM24	105	265	385	82	410	12xM24	105
350	283	455	92	490	16xM24	154	305	415	92	470	16xM24	154
400	325	480	102	550	16xM27	202	335	470	102	525	16xM27	202
500	375	580	127	660	20xM30	231	405	535	127	650	20xM30	231
600	430	640	154	770	20xM33	318	450	610	154	770	20xM33	318
700	540	720	165	875	24xM33	490	520	680	165	840	24xM33	490
800	710	820	190	990	24xM36	715	590	750	190	950	24xM36	715
900	650	800	203	1090	28xM36	1000	650	800	203	1050	28xM36	1000
1000	720	940	216	1210	28xM39	1349	720	920	216	1170	28xM39	1349

DN	PN25						PN40					
	Dimensions, mm					Weight with gearbox, kg	Dimensions, mm					Weight with gearbox, kg
	A	B	L	D1	n*M		A	B	L	D1	n*M	
50	65	175	43	125	4xM16	16	80	175	43	125	4xM16	18
65	75	190	46	145	8xM16	17	90	190	46	145	8xM16	19
80	90	195	49	160	8xM16	19	105	195	64	160	8xM16	22
100	117	215	52	190	8xM20	22	117	220	64	190	8xM20	25
125	135	250	56	220	8xM24	36	155	260	70	220	8xM24	42
150	176	270	61	250	8xM24	47	175	320	76	250	8xM24	61
200	185	320	64	310	12xM27	62	220	330	89	320	12xM27	71
250	215	360	71	370	12xM27	78	250	370	114	385	12xM30	115
300	250	395	82	430	16xM27	139	300	435	114	450	16xM30	159
350	283	455	92	490	16xM30	165	330	480	127	510	16xM33	251
400	325	480	102	550	16xM33	263	340	535	140	585	16xM36	314
500	375	580	127	660	20xM33	311	415	610	152	670	20xM39	353
600	430	640	154	770	20xM36	357	480	630	178	795	20xM45	428
700	540	720	165	875	24xM39	548	550	730	229	900	24xM45	634
800	710	820	190	990	24xM45	774	620	810	241	1030	24xM52	1054
900	650	800	203	1090	28xM45	1238						
1000	720	940	216	1210	28xM52	1457						

Top flange's dimensions and torque for choosing actuator*

DN	PN10		PN16		PN25		PN40	
	Top flange acc. to ISO	Torque, H*m	Top flange acc. to ISO	Torque, H*m	Top flange acc. to ISO	Torque, H*m	Top flange acc. to ISO	Torque, H*m
50	F07	24	F07	24	F07	29	F07	70
65	F07	35	F07	35	F07	42	F07	95
80	F07	54	F07	54	F07	65	F07	110
100	F07	88	F07	88	F07	106	F07	180
125	F10	130	F10	130	F10	156	F10	290
150	F10	200	F10	200	F10	240	F12	470
200	F10	340	F10	340	F10	340	F12	820
250	F12	570	F12	570	F12	684	F14	1340
300	F12	835	F12	835	F12	1002	F14	2000
350	F14	1180	F14	1180	F14	1416	F16	2820
400	F16	1740	F16	1740	F16	2088	F25	4400
500	F16	3050	F16	3050	F16	3660	F25	7660
600	F25	5450	F25	5450	F25	6540	F30	13220
700	F25	8000	F25	8000	F25	9600	F35	19400
800	F30	10600	F30	10600	F30	12720	F35	28300
900	F30	14500	F30	14500	F30	17400		
1000	F35	19200	F35	19200	F35	23040		

* the shape and size of stem specify in the request

Flow capacity of valves Kv, m³/h

DN	50	65	80	100	125	150	200	250	300
Kv	88	136	158	320	678	1160	2414	3685	5681
DN	350	400	450	500	600	700	800	900	1000
Kv	6525	8376	8974	11558	17060	23969	39087	41456	52971

Reliability parameters of butterfly valves

DN	40-100	125,150	200-300	350,400	450-600	700-900	1000,1200
Mean life, cycles, not less	5200	4200	3800	3200	2200	1800	1700
Warranty life, cycles, not less than	1900	1600	1500	1300	900	700	550

Average life and warranty life of the sealing materials identified when testing valves with water according to GOST 2874-82

When operating valves for working mediums other than water, the reliability parameters are determined by the specific mediums, depending on its parameters.

Warranty

The warranty period is 18 months from the date of putting into operation, but not more than 24 months from the date of sale under condition of observance by the consumer of rules of transportation, installation and operation.

Conservation period - 3 years.

Average service life of body parts is not less than 30 years.

Average life removable parts and components – at least 5 years.

BUTTERFLY VALVES SERIES PA600



Valves of this series are designed and manufactured taking into account the European requirements for design, construction and quality.

A distinctive feature of the butterfly valves series PA600 is a soft seat with no hard ring-base, without pin connection between disc and stem. Valve stem fastening in the body excludes its "pulling out" during operation. Valves may be installed in any spatial position.

The design of valves series PA600 is ergonomic, reliable and compact. The design and technological solutions allow repair and maintenance of the valve, replacement of the seat and disk without special equipment and fittings by the technical staff of operating organizations.

Valves series PA600 series are equipped with various versions of electric, pneumatic actuators, sets of mating flanges and fasteners, as required by the customer.

Manufacture and supply:	Acc. to TU 3700-001-55604618-2013
Type of construction:	Butterfly valve with symmetric disk, seat material - soft elastomer
Nominal diameter:	DN 25 – DN 1200 mm
Nominal pressure:	PN 6, 10, 16 kgf/cm ²
Temperature of working medium:	Up to +180°C depending on the seat material
Operation:	– handle DN 40-200 mm – gearbox DN 40-1200 mm – electric or pneumatic actuator DN 40-1200 mm
Leakage class:	«A» acc. to GOST 9544-2015
Main working mediums:	Water, air, natural gas and gaseous products, ammonia gas, petroleum products, hydrocarbons, acids, alkalis, alcohols, sea water
Connection type:	– wafer type with smooth lugs; – wafer type with threaded lugs; Connecting flanges according to GOST 33259-2015
Installation position:	Any, except the position "electric actuator down" for valves with electric actuator
Flow direction of the working mediums:	Any
Flow rate of the working medium:	Up to 80 m/s for gases, up to 5 m/s for liquids
Climatic version:	V, YXA, T, TM, TB acc. to GOST 15150-69
Flow characteristic of valves:	Equal percentage, when opening angles of the disk from 20° to 70° With opening angles up to 60-70° valves can be used for throttling the flow of working medium
Top flange:	Acc. to ISO 5211

PromArm LLC reserves the right to make changes to the design not affecting functional characteristics of the equipment.

Classification of butterfly valves series PA600

Valve design:

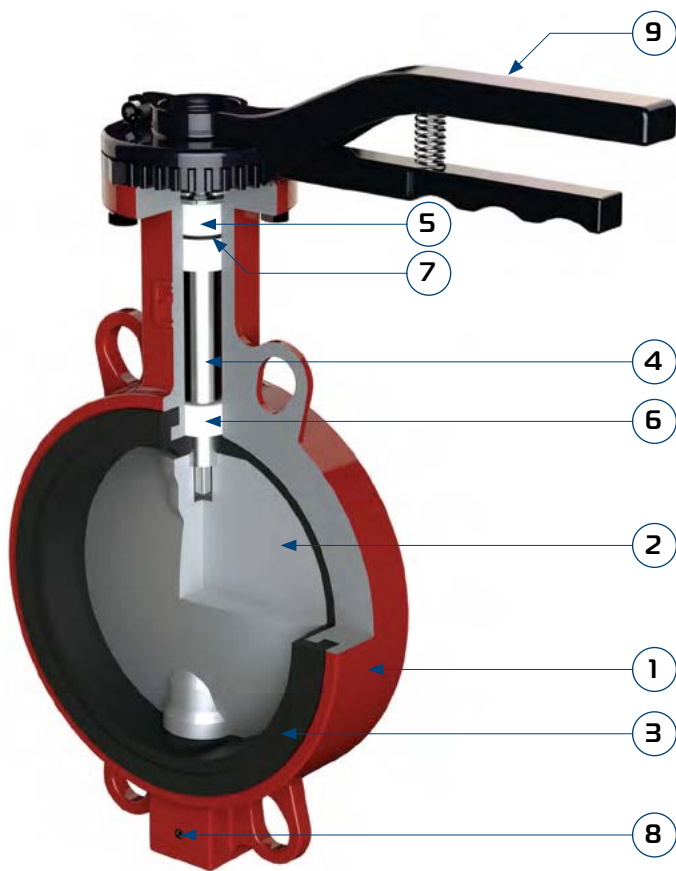

Position	Description
1	Body
2	Disk
3	Seat
4	Stem
5,6	Bushing
7	O-ring
8	Rod
9	Handle

Seat materials	Description
NBR	- resistance to oils, lubricants, fuels, natural gas; - not resistant to alkali and acid environments, water vapor
EPDM	- resistance to oils, gasoline, diesel fuel, diluted acids and alkalis - not resistant to fuels and lubricants, fats
Viton	- resistance to oils, gasoline, diesel fuel, diluted acids and alkalis of medium concentration; - not resistant to ketones, hot water, steam
Silicon	- general resistance to oxidizers. Works well in hot air and gases.

Designation

PA	1	2	3	DN	PN	-	4	5	Series	6
									Disk material	1
									Seat material	2
									Body material	3
									Connection type	4
										5
										6
										7
										8
										9
										01
										02
										03
										04
										-
										P

Example:

PA652.100.16-01

- series PA600,
- disk of stainless steel with molybdenum,
- seat - EPDM,
- DN100 mm, PN16 kgf/cm²,
- body of ductile cast iron

When choosing the material of the disk and seat for real working parameters, it is recommended to consult with the employees of PromArm Company.

Main overall and connection dimensions Wafer type connection with smooth lugs

DN 40-200 mm with handle

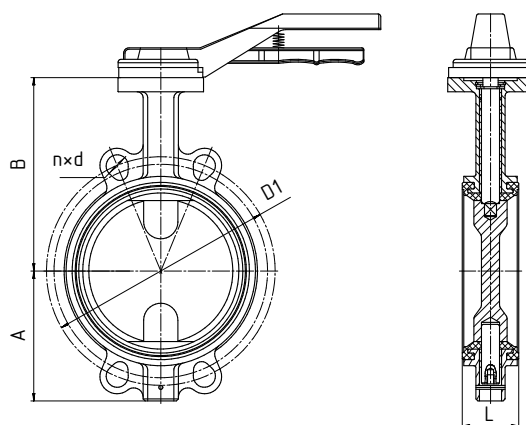

DN	Dimensions, mm						Weight with handle, kg	
	A	B	L	D1		n*d		
				PN10	PN16	PN10		PN16
40	70	133	33	110	110	Four universal holes for PN10, 16	2,5	
50	61	141	43	125	125		2,7	
65	72	153	46	145	145		3,1	
80	87	161	46	160	160		3,5	
100	106	179	52	180	180		4,9	
125	123	193	56	210	210		6,6	
150	137	204	56	240	240		7,1	
200	174	247	60	295	295		13,6	

DN 40 – 600 mm with gearbox

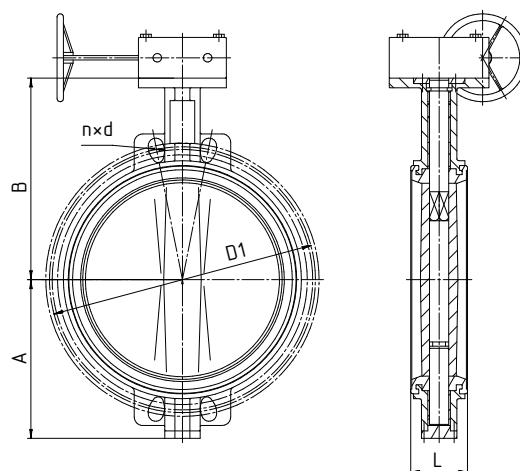

DN	Dimensions, mm						Weight with gearbox, kg	
	A	B	L	D1		n*d		
				PN10	PN16	PN10		PN16
40	70	133	33	110	110	Four universal holes for PN10, 16	3,5	
50	61	141	43	125	125		3,7	
65	72	153	46	145	145		4,1	
80	87	161	46	160	160		4,5	
100	106	179	52	180	180		5,9	
125	123	193	56	210	210		8,5	
150	137	204	56	240	240		10	
200	174	247	60	295	295		16	
250	209	280	68	350	355		25	
300	253	324	78	400	410		34	
350	260	368	78	460	470		61	
400	315	400	102	515	525		67	
500	379	485	127	620	650		98	
600	440	565	154	725	770		143	

Wafer type with threaded lugs

DN 40-200 mm with handle

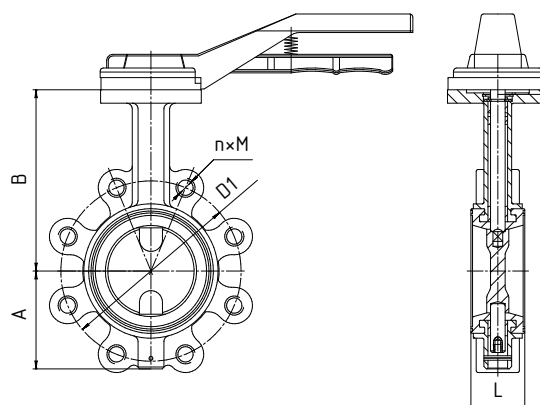

DN	Dimensions, mm							Weight with handle, kg
	A	B	L	D1		n*M		
				PN10	PN16	PN10	PN16	
40	70	133	33	110	110	4xM16	4xM16	2,8
50	62	141	43	125	125	4xM16	4xM16	3
65	72	153	46	145	145	4xM16	4xM16	4
80	87	161	46	160	160	8xM16	8xM16	5,1
100	106	178	52	180	180	8xM16	8xM16	7
125	123	193	56	210	210	8xM16	8xM16	8,6
150	138	204	56	240	240	8xM20	8xM20	9,3
200	173	247	60	295	295	8xM20	12xM20	17,5

DN 40-600 mm with gearbox

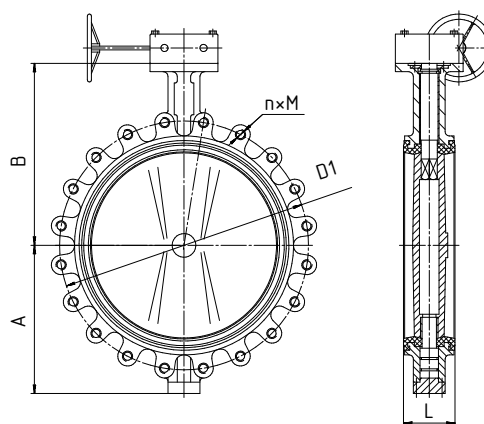

DN	Dimensions, mm							Weight with gearbox, kg
	A	B	L	D1		n*M		
				PN10	PN16	PN10	PN16	
40	70	133	33	110	110	4xM16	4xM16	3,8
50	62	141	43	125	125	4xM16	4xM16	4
65	72	153	46	145	145	4xM16	4xM16	5,1
80	87	161	46	160	160	4xM16	4xM16	6,5
100	106	170	52	180	180	8xM16	8xM16	7,5
125	123	193	56	210	210	8xM16	8xM16	10
150	138	204	56	240	240	8xM20	8xM20	12,3
200	173	247	60	295	295	8xM20	12xM20	21,4
250	207	280	68	350	355	12xM20	12xM24	31
300	250	324	78	400	410	12xM20	12xM24	53
350	267	368	78	460	470	16xM20	16xM24	65
400	312	400	102	515	525	16xM24	16xM27	87
450	350	425	114	565	585	20xM24	20xM27	125
500	363	485	127	620	650	20xM24	20xM30	175
600	459	565	154	725	770	20xM27	20xM33	253

Top flange's dimensions and torque for choosing actuator

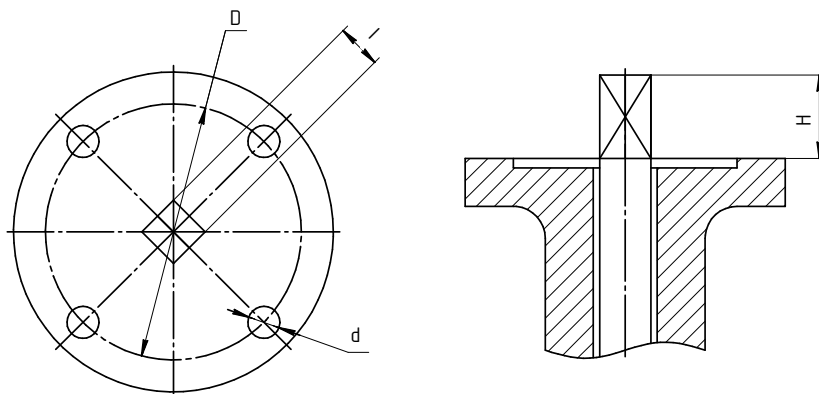

DN	Top flange acc. to ISO	Dimensions, mm				Torque, H*m	
		D	d	l	H	PN10	PN16
40	F07	70	10	11	25	10	10
50	F07	70	10	11	25	19	19
65	F07	70	10	11	25	22	22
80	F07	70	10	11	25	54	54
100	F07	70	10	11	25	66	66
125	F07	70	10	14	25	78	78
150	F07	70	10	14	25	120	120
200	F10	102	12	17	35	228	228
250	F10	102	12	22	30	388	388
300	F10	102	12	22	30	588	588
350	F10	102	12	22	45	750	750
400	F14	140	18	27	50,8	1320	1320
450	F14	140	18	27	50,8	1440	1440
500	F14	140	18	32	57,5	1680	1680
600	F16	165	23	36	70	2640	2640

The dimensions and torque is approximate, for correct selection of electrical and pneumatic actuators it is recommended to consult with the representatives of PromArm company.

Flow capacity of valves Kv, m³/h

DN	40	50	65	80	100	125	150	200	250	300
Kv	68	145	225	325	590	1125	1950	3250	5000	7500
DN	350	400	450	500	600	700	800	900	1000	1200
Kv	8620	10416	15215	18959	24869	36200	44300	58000	80600	110500

Reliability parameters of butterfly valves

DN	40-100	125,150	200-300	350,400	450-600	700-900	1000,1200
Mean life, cycles, not less	5500	4500	4100	3500	2500	2100	2000
Warranty life, cycles, not less than	2100	1800	1700	1500	1100	900	750

Average life and warranty life of the sealing materials identified when testing valves with water according to GOST 2874-82

When operating valves for working mediums other than water, the reliability parameters are determined by the specific mediums, depending on its parameters.

Warranty

The warranty period is 18 months from the date of putting into operation, but not more than 24 months from the date of sale under condition of observance by the consumer of rules of transportation, installation and operation. Conservation period - 3 years.

Average service life of body parts is not less than 30 years.

Average life removable parts and components – at least 5 years.

BUTTERFLY VALVES WITH DOUBLE OFFSET SERIES PA700



Structurally valves of series PA700 are made with a double offset of the disk - relative to the valve body axis and the pipeline axis. This design reduces wear of the seat parts and reduces the torque required to open and close the valve. A soft seat of EPDM, NBR or Viton is manufactured in the form of a removable O-ring on the disc, which simplifies its quick replacement in case of wear and extends the valve service life. With opening angles up to 20-70° valves can be used for throttling the flow of working medium. Connection type is flanged. Valves are designed for installation on process pipelines in metallurgical, gas processing, petrochemical, oil refining, chemical industries, fuel and energy complex enterprises, housing and utilities facilities, water supply and sanitation systems.

Manufacture and supply:	Acc. to TU 3700-001-55604618-2013
Type of construction:	Flanged butterfly valves with double offset and elastomer seat
Nominal diameter:	DN 50 – DN 2400 mm
Nominal pressure:	PN 6, 10, 16, 25 kgf/cm ²
Temperature of working medium:	Up to +200°C depending on the seat material
Operation:	– gearbox DN 100-2400 mm – electric or pneumatic actuator DN 100-2400 mm
Leakage class:	«A» acc. to GOST 9544-2015
Main working mediums:	Water, oil, oil products, water-gas-oil mixtures, drainage and sewage, sea water
Connection type:	– flanged Connecting flanges according to GOST 33259-2015
Installation position:	Any, except the position "electric actuator down" for valves with electric actuator
Flow direction of the working mediums:	Unidirectional, along the arrow on the valve body, bidirectional upon request
Flow rate of the working medium:	Not more than 1,0-5,0 m/s (for liquids)
Climatic version:	V, VXA, T, TM, TB acc. to GOST 15150-69
Top flange:	Acc. to ISO 5211

Classification of butterfly valves series PA700

Valve design:

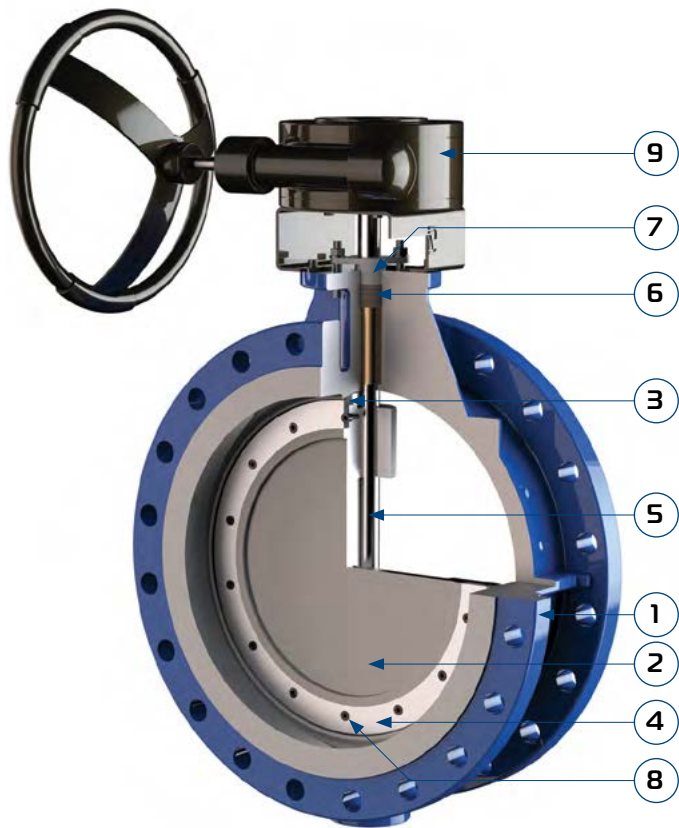

Position	Description
1	Body
2	Disk
3	Seat
4	Pressure ring
5	Stem
6	Packing
7	Packing gland flange
8	Bolt
9	Gearbox

Seat materials	Description
NBR	- resistance to oils, lubricants, fuels, natural gas; - not resistant to alkali and acid environments, water vapor
EPDM	- resistance to water, alkalis, acids, abrasive materials, air; - not resistant to fuels and lubricants, fats
Viton	- resistance to oils, gasoline, diz.fuel, diluted acids and alkalis of medium concentration; - not resistant to hot water, steam
PTFE	Universal thermal and chemical resistance

Designation

ПА 1 2 3 DN PN - 4

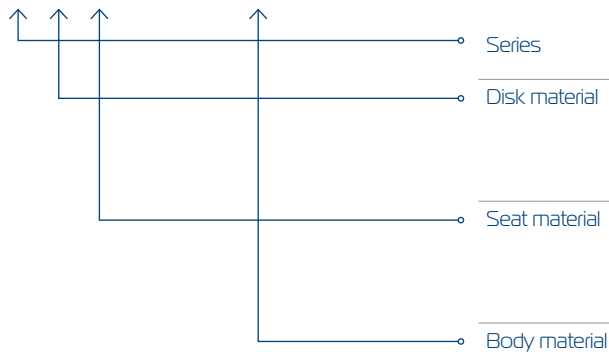

Example:
PA721.100.16-02

- series PA700,
- disk of carbon steel,
- seat - NBR,
- DN100 mm, PN16 kgf/cm²,
- body of carbon steel,

7	PA700 – butterfly valves with double offset and elastomer seat
2	Carbon steel
3	Ductile cast iron
4	Stainless steel
5	Stainless steel with molybdenum
1	NBR
2	EPDM
3	VITON
4	PTFE
01	Ductile cast iron
02	Carbon steel
04	Stainless steel

When choosing the material of the disk and seat for real working parameters, it is recommended to consult with the employees of PromArm Company.

Sealing diagram in butterfly valves with double offset

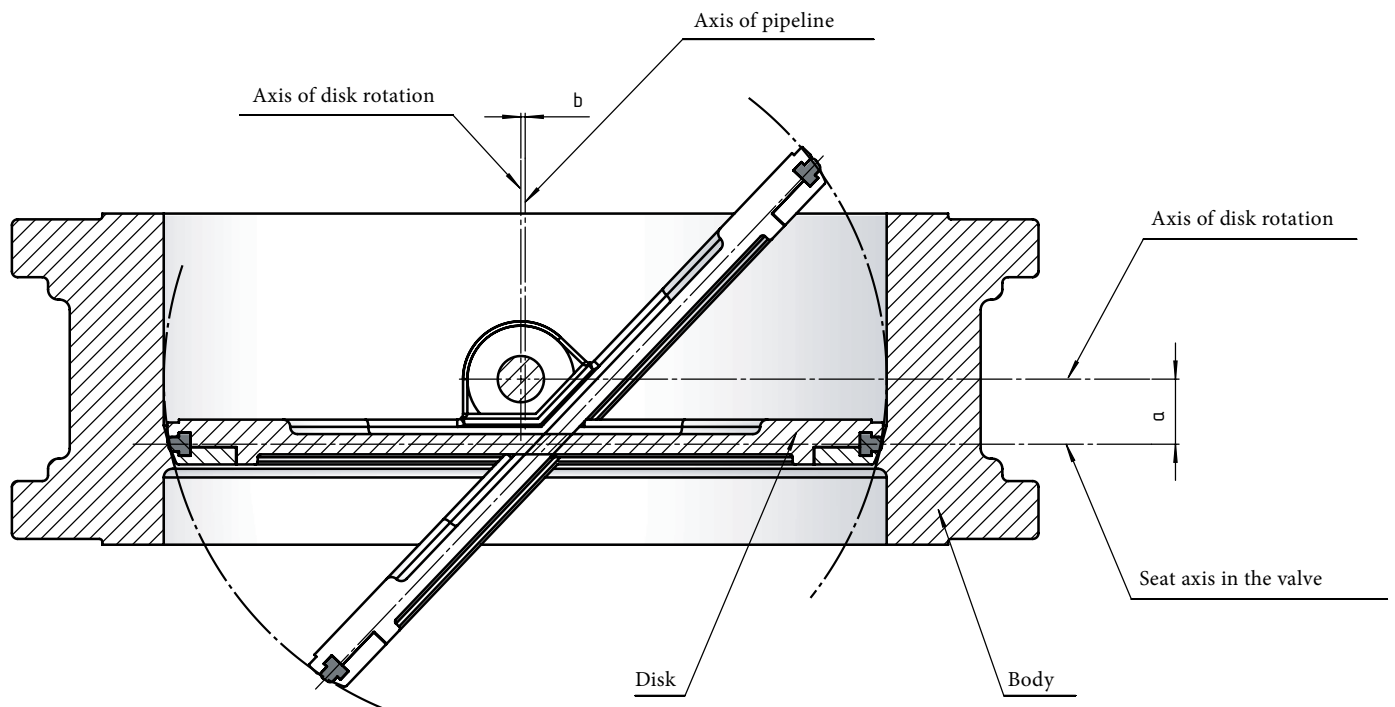

This figure shows the design of butterfly valves with double offset: offset "a" is the offset of the disk axis of rotation relative to the seat axis in the valve; offset "b" is the offset of the disk axis of rotation from the pipeline axis. This design reduces friction in the points of contact between the disk and the seat, which increases reliability and durability of these valves, reduces the torque to control the valve.

Sealing diagram

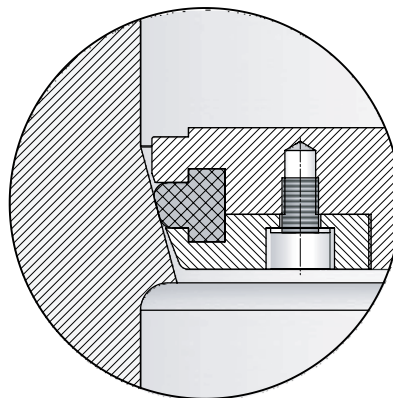

The seat consists of an elastic ring with a T-shaped profile, fixed to the rim of the disk by a pressure ring. In the closed position, the ring is pressed against the seat having a conical shape. This ensures two-sided seat tightness.

Main overall and connection dimensions

Flanged connection

DN 50-500 mm with gearbox

DN 600-2400 mm with gearbox

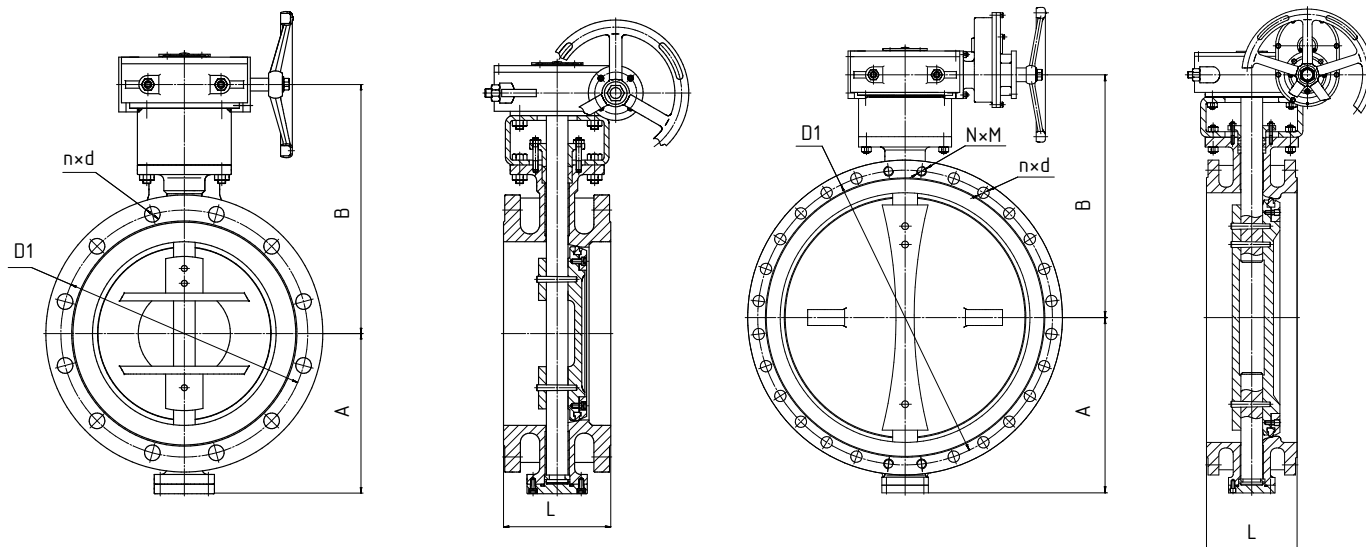

DN	PN10							
	Dimensions, mm							
	A	B	L		D1	n*d	Weight with gearbox, kg	
		short	long			short	long	
50	82,5	150	108	150	125	4x18	16	20
65	92,5	165	112	170	145	4x18	17	21
80	100	170	114	180	160	8x18	17	21
100	95	230	127	190	180	8x18	25	30
125	110	257	140	200	210	8x18	28	34
150	150	300	140	210	240	8x22	32	38
200	200	350	152	230	295	8x22	42	50
250	240	370	165	250	350	12x22	60	72
300	270	427	178	270	400	12x22	90	108
350	310	450	190	290	460	16x22	130	156
400	352	525	216	310	515	16x26	190	228
450	360	543	222	330	565	20x26	250	300
500	390	585	229	350	620	20x26	300	360
600	450	643	267	390	725	20x30	430	516
700	520	737	292	430	840	24x30	500	600
800	590	885	318	470	950	24x33	690	828
900	640	975	330	510	1050	28x33	950	1140
1000	710	1130	410	550	1160	28x33	1080	1296
1200	835	1220	470	630	1380	32x39	1900	2280
1400	1000	1430	530	710	1590	36x45	2600	3120
1600	1080	1500	600	790	1820	40x52	3500	4200
1800	1215	1650	670	870	2020	44x52	4500	5400
2000	1330	1720	760	950	2230	48x52	6100	7320
2200	1530	1900	800	1000	2440	52x56	7100	8520
2400	1625	2070	850	1100	2650	56x56	8800	10560

DN	PN16							
	Dimensions, mm							
	A	B	L		D1	n*d	Weight with gearbox, kg	
short			long	short			long	
50	82,5	150	108	150	125	4x18	16	20
65	92,5	165	112	170	145	4x18	17	21
80	100	170	114	180	160	8x18	17	21
100	95	230	127	190	180	8x18	25	30
125	110	257	140	200	210	8x18	28	34
150	150	300	140	210	240	8x22	32	38
200	200	350	152	230	295	12x22	42	50
250	240	370	165	250	355	12x26	60	72
300	270	427	178	270	410	12x26	90	108
350	310	450	190	290	470	16x26	130	156
400	352	525	216	310	525	16x30	190	228
450	360	543	222	330	585	20x30	250	300
500	390	585	229	350	650	20x33	300	360
600	450	643	267	390	770	20x39	430	516
700	520	737	292	430	840	24x39	500	600
800	590	885	318	470	950	24x39	690	828
900	640	975	330	510	1050	28x39	950	1140
1000	710	1130	410	550	1170	28x45	1080	1296
1200	835	1220	470	630	1390	32x52	1900	2280
1400	1000	1430	530	710	1590	36x52	2600	3120
1600	1080	1500	600	790	1820	40x56	3500	4200
1800	1215	1650	670	870	2020	44x56	4500	5400
2000	1330	1720	760	950	2230	48x62	6100	7320
2200	1530	1900	800	1000	2440	52x62	7100	8520
2400	1625	2070	850	1100	2650	56x62	8800	10560

DN	PN25						
	Dimensions, mm						
	A	B	L	D1	n*d	Weight with gearbox, kg	
200	200	350	230	310	12x26	50	
250	240	370	250	370	12x30	72	
300	270	427	270	430	16x30	108	
350	310	450	290	490	16x33	156	
400	352	525	310	550	16x33	228	
450	360	543	330	600	20x33	300	
500	390	585	350	660	20x39	360	
600	450	643	390	770	20x39	516	
700	520	737	430	875	24x45	600	
800	590	885	470	990	24x45	828	
900	640	975	510	1090	28x52	1140	
1000	710	1130	550	1210	28x56	1296	
1200	835	1220	630	1420	32x56	2280	
1400	1000	1430	710	1640	36x62	3120	
1600	1080	1500	790	1860	36x62	4200	

Top flange's dimensions and torque for choosing actuator

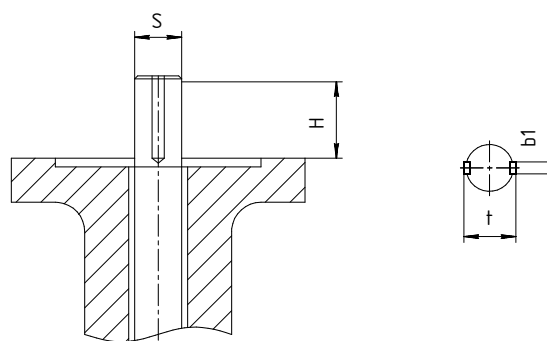

DN	PN10		PN16		PN25	
	Top flange acc. to ISO	Torque, H*m	Top flange acc. to ISO	Torque, H*m	Top flange acc. to ISO	Torque, H*m
50	F07	50	F07	50	F07	70
65	F07	80	F07	80	F07	90
80	F07	105	F07	105	F07	120
100	F07	100	F07	160	F07	250
125	F07	150	F07	230	F07	360
150	F07	200	F07	320	F07	480
200	F12	297	F12	422	F12	652
250	F12	498	F12	711	F12	1099
300	F12	779	F12	1122	F12	1700
350	F12	1122	F12	1621	F12	2484
400	F14	1548	F14	2247	F14	3445
450	F14	2060	F14	3002	F14	4609
500	F16	2563	F16	3899	F16	5990
600	F25	4211	F25	6158	F25	9827
700	F25	6189	F25	9106	F25	14513
800	F25	8683	F25	12845	F25	20444
900	F25	11463	F25	17038	F25	27088
1000	F30	15553	F30	23145	F30	38672
1200	F30	25020	F30	37507	F35	62260
1400	F35	37594	F35	59348	F40	89461
1600	F40	53749	F40	84939	F48	128416
1800	F40	75789	F48	119398		180446
2000	F48	100777	F48	158931		
2200	F60	130633		206205		
2400	F60	165741		261843		

The data is approximate, for correct selection of electrical and pneumatic actuators it is recommended to consult with the representatives of PromArm company. Stem dimensions and shape are clarified upon request. For DN500 and higher, installation of multiturn actuators through worm gearbox is possible.

Flow capacity of valves Kv, m³/h

DN	100	125	150	200	250	300	350	400	450	500	600
Kv	620	930	1310	2500	4080	6030	8410	11140	14270	17800	24843
DN	700	800	900	1000	1200	1400	1600	1800	2000	2400	
Kv	35362	46870	58632	72610	104985	144850	190354	239050	296460	429820	

Reliability parameters of butterfly valves

DN	40-100	125,150	200-300	350,400	450-600	700-900	1000-1800
Mean life, cycles, not less	5200	4200	3800	3200	2200	1800	1700
Warranty life, cycles, not less than	1900	1600	1500	1300	900	700	550

Average life and warranty life of the sealing materials identified when testing valves with water according to GOST 2874-82

When operating valves for working mediums other than water, the reliability parameters are determined by the specific mediums, depending on its parameters.

Warranty

The warranty period is 18 months from the date of putting into operation, but not more than 24 months from the date of sale under condition of observance by the consumer of rules of transportation, installation and operation.

Conservation period - 3 years.

Average service life of body parts is not less than 30 years.

Average life removable parts and components – at least 5 years.

BUTTERFLY VALVES WITH TRIPLE OFFSET SERIES PA900



Butterfly valves with triple offset series PA900 are designed for installation on pipelines as shut-off and control valves.

Triple offset in the valve design minimizes frictional losses during opening and closing, reducing the torque on the stem required for control.

The use of prefabricated metal-graphite or all-metal seat in valves series PA900 allows to operate them under high pressure and temperature conditions, which is an important advantage over valves with elastomer seat.

With opening angles up to 20-70° valves can be used for adjusting the flow of working medium

These valves are widely used in process pipelines in power engineering, metallurgy, oil, oil refining, petrochemical, chemical industries, water supply and sanitation facilities, and utilities.

Manufacture and supply:	Acc. to TU 3700-001-55604618-2013
Type of construction:	Butterfly valves with triple offset
Nominal diameter:	DN 50 – DN 2000 mm
Nominal pressure:	PN 6 , 10, 16, 25, 40, 63, 100 kgf/cm ²
Temperature of working medium:	Up to +500°C depending on the seat material
Operation:	– gearbox DN 50-2000 mm – electric or pneumatic actuator DN 50-2000 mm
Leakage class:	«A» acc. to GOST 9544-2015
Main working mediums:	Water, air, steam, natural gas and gaseous hydrocarbons, petroleum, petroleum products, coke oven gas, ammonia, acids, alkalis, alcohols
Connection type:	– wafer type with smooth lugs; – flanged; – welded. Connecting flanges according to GOST 33259-2015
Installation position:	Any, except the position "electric actuator down" for valves with electric actuator
Flow direction of the working mediums:	Unidirectional, along the arrow on the valve body, bidirectional upon request
Climatic version:	V, VXA, T, TM, TB acc. to GOST 15150-69
Top flange:	Acc. to ISO 5211

Classification of butterfly valves series PA900

Valve design:

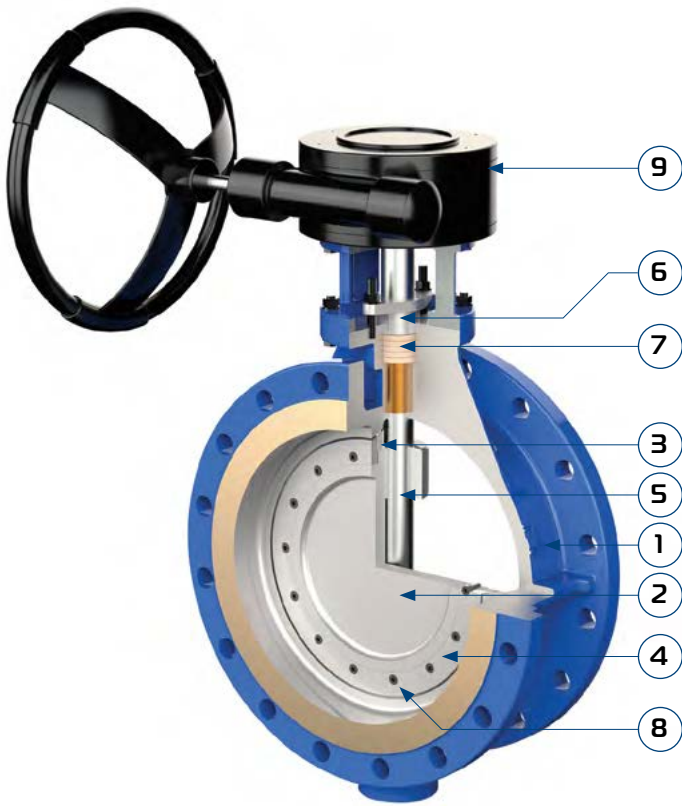

Position	Description
1	Body
2	Disk
3	Seat
4	Pressure ring
5	Stem
6	Packing gland flange
7	Packing
8	Bolt
9	Gearbox

Seat materials	Description
Steel SS304 +graphite	Metal-on-metal seat - stack seat of graphite and stainless steel rings
Steel SS304	Metal-on-metal seat is all-metal, used at high temperatures
PTFE	Universal thermal and chemical resistance

Designation

Series	Description
9	PA900 – butterfly valves with triple offset
2	Carbon steel
4	Stainless steel
5	Stainless steel with molybdenum
6	Construction alloyed steel
4	PTFE
6	SS304+graphite – corrosion resistant steel + graphite (Metal-on-metal seat - stack seat of graphite and stainless steel rings)
7	SS304 – corrosion resistant steel (Metal-on-metal seat is all-metal)
8	Metal-on-metal seat - stack seat of graphite and stainless steel rings - two-side tightness
02	Carbon steel
04	Stainless steel
05	Stainless steel with molybdenum
06	Construction alloyed steel
-	Wafer type with smooth lugs
P	Wafer type with threaded lugs
Φ	Flanged
Π	Welded

Example:

PA926.300.16-02Φ

- series PA900,
- disk of carbon steel,
- seat - stainless steel + graphite –
- DN300 mm, PN16 kgf/cm²,
- body of carbon steel,
- flanged.

When choosing the material of the disk and seat for real working parameters, it is recommended to consult with the employees of PromArm Company.

Sealing diagram in butterfly valves with triple offset

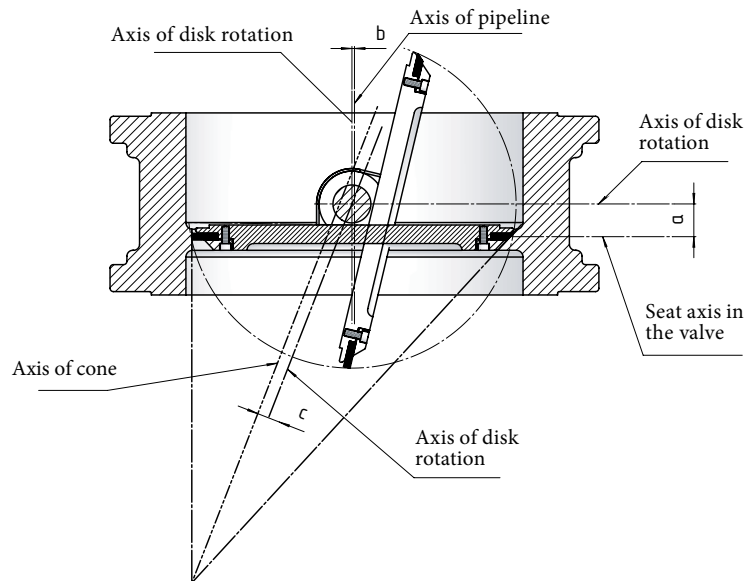

This figure shows the design of valves with triple offset: the disk axis of rotation and the seat axis in the valve create offset "a"; the disk axis of rotation is offset from the pipeline axis - this is offset "b"; the third offset "c" is formed due to the conical shape of the sealing surface. This design reduces friction in the points of contact between the disk and the seat, which increases reliability and durability of these valves, reduces the torque to control the valve.

Seat types

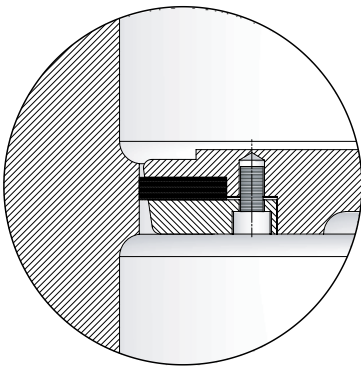

Metal-on-metal seat - stack seat of graphite and stainless steel rings

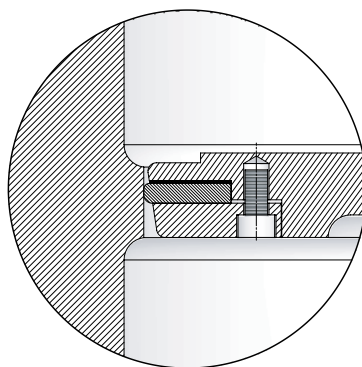

Metal-on-metal seat is all-metal

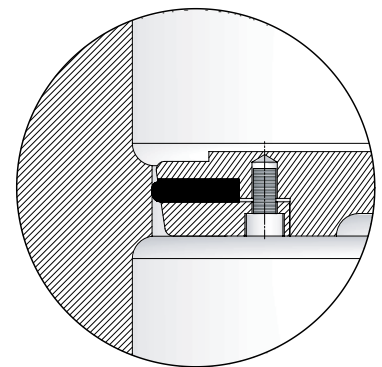

PTFE seat

By default, valves series PA900 have one-sided tightness, i.e. the direction of the working medium must be unidirectional, in accordance with the arrow on the body. It is not allowed to use such valves to block the flow of the working medium in the opposite direction, this can lead to valve breakage. Although in exceptional cases, after agreement with the manufacturer, it is possible to use these valves for the return flow of the working medium with a pressure less than the nominal pressure. Upon request, it is possible to manufacture bidirectional valves series PA900 for any flow direction of the working medium.

This is achieved by using stronger parts of the valve design, such as the stem, bearings, gearbox, etc. Valves series PA900 with double-sided tightness have a seat designation = 8.

For example, PA928.500.16-02F is a "rotary disk flanged valve with triple offset (body – steel WCB, disk – steel WCB, seat – stainless steel + graphite, direction of working medium - bidirectional) with gearbox".

Main overall and connection dimensions Wafer type connection with smooth lugs

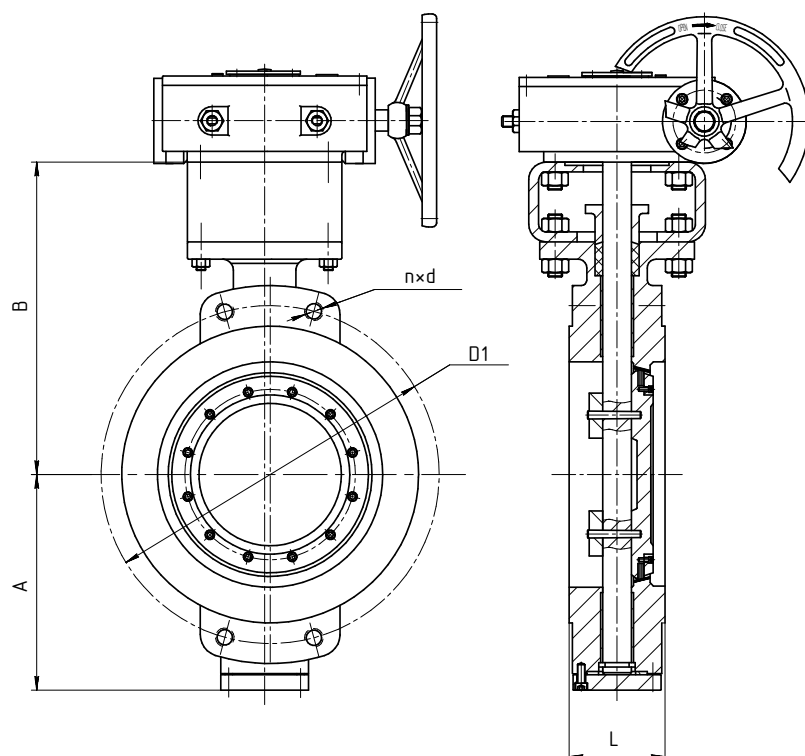

DN	PN10						PN16					
	Dimensions, mm					Weight with gearbox, kg	Dimensions, mm					Weight with gearbox, kg
	A	B	L	D1	n*d		A	B	L	D1	n*d	
50	70	235	43	125	4x18	11	70	235	43	125	4x18	11
65	75	250	46	145	4x18	12	75	250	46	145	4x18	12
80	85	150	49	160	4x18	13	85	250	49	160	4x18	13
100	100	260	56	180	8x18	14	100	260	56	180	8x18	14
125	110	280	64	210	8x18	21	110	280	64	210	8x18	21
150	150	310	70	240	8x22	25	150	310	70	240	8x22	25
200	210	380	71	295	8x22	38	210	380	71	295	12x22	38
250	235	395	76	350	12x22	60	235	395	76	355	12x26	60
300	265	425	83	400	12x22	76	265	425	83	410	12x26	76
350	300	480	92	460	16x22	109	300	480	92	470	16x26	109
400	355	535	102	515	16x26	130	355	535	102	525	16x30	130
450	380	570	114	565	20x26	135	380	570	114	585	20x30	135
500	395	590	127	620	20x26	206	395	590	127	650	20x33	206
600	450	675	154	725	20x30	312	450	675	154	770	20x39	312
700	520	770	165	840	24x30	369	520	770	165	840	24x39	369
800	590	840	190	950	24x33	570	590	840	190	950	24x39	570
900	660	915	203	1050	28x33	750	660	915	203	1050	28x39	750
1000	730	1050	216	1160	28x33	930	730	1050	216	1170	28x45	930
1200	870	1190	254	1380	32x39	1183	870	1190	254	1390	32x52	1183
1400	1015	1350	279	1590	32x45	1415						

DN	PN25						PN40					
	Dimensions, mm					Weight with gearbox, kg	Dimensions, mm					Weight with gearbox, kg
	A	B	L	DI	n*d		A	B	L	DI	n*d	
50	70	235	43	125	4x18	11	80	250	43	125	4x18	12
65	75	250	46	145	8x18	13	85	265	46	145	8x18	14
80	85	250	49	160	8x18	14	95	265	64	160	8x18	15
100	100	260	56	190	8x22	16	115	275	64	190	8x22	17
125	110	280	64	220	8x26	22	125	295	70	220	8x26	25
150	150	310	70	250	8x26	32	165	330	76	250	8x26	36
200	210	380	71	310	8x26	48	225	395	89	320	12x30	50
250	235	395	76	370	8x30	68	250	410	114	385	12x33	79
300	265	425	83	430	12x30	98	285	450	114	450	16x33	128
350	300	480	92	490	12x33	112	330	510	127	510	16x33	233
400	355	535	102	550	12x33	145	390	570	140	585	12x39	272
450	380	570	114	600	16x33	198	415	595	152	610	16x39	307
500	395	590	127	660	16x39	287	430	625	152	670	16x45	378
600	450	675	154	770	16x39	405	485	710	178	795	16x52	465
700	520	770	165	875	20x45	461	535	810	229	900	20x52	679
800	590	840	190	990	20x45	712	630	890	241	1030	20x56	817
900	660	915	203	1090	24x52	832						
1000	730	1050	216	1210	24x56	1270						
1200	870	1190	254	1420	28x56	1464						

DN	PN63						PN100					
	Dimensions, mm					Weight with gearbox, kg	Dimensions, mm					Weight with gearbox, kg
	A	B	L	DI	n*d		A	B	L	DI	n*d	
50	80	250	43	135	4x22	17						
65	85	265	46	160	8x22	19						
80	95	265	64	170	8x22	20						
100	115	275	64	200	8x26	23	115	275	64	210	8x30	26
125	125	295	78	240	8x30	34	125	295	78	250	8x33	38
150	165	330	78	280	8x33	49	165	330	78	290	12x33	56
200	225	395	102	345	8x33	62	225	395	102	360	8x39	96
250	250	410	117	400	8x39	115	250	410	117	430	8x39	130
300	285	450	140	460	12x39	207	285	450	140	500	12x45	227
350	330	510	155	525	12x39	259	330	510	155	560	12x52	290
400	390	570	178	585	12x45	326	390	570	178	620	12x52	367
500	430	625	216	705	16x52	429						
600	485	710	232	820	16x56	684						

Flange type connection

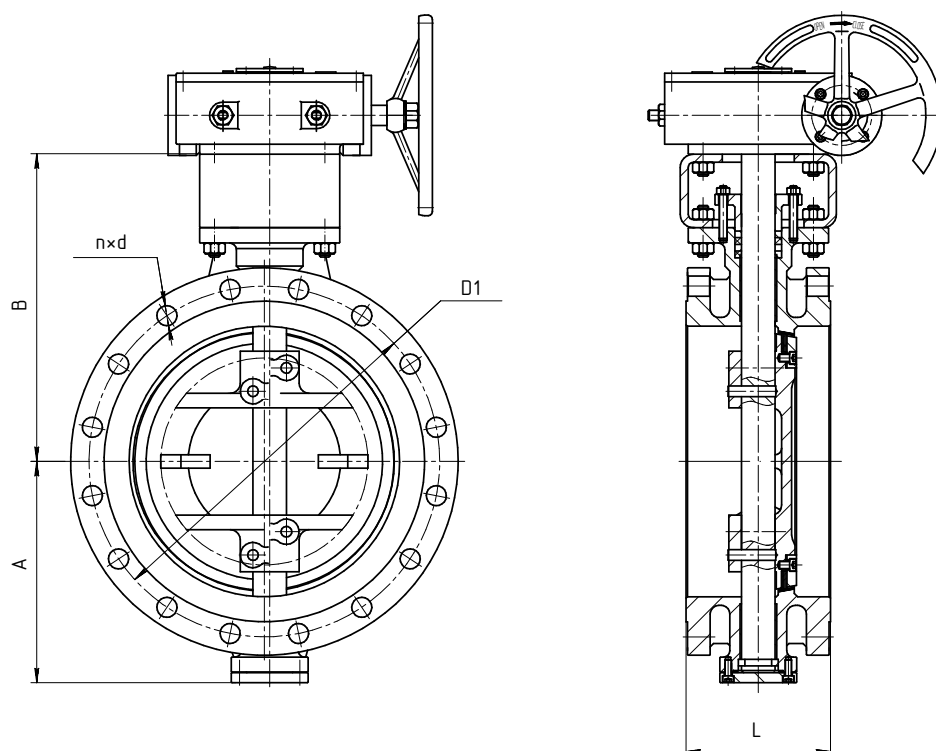

DN	PN10						PN16					
	Dimensions, mm					Weight with gearbox, kg	Dimensions, mm					Weight with gearbox, kg
	A	B	L	D1	n*d		A	B	L	D1	n*d	
50	70	235	108	125	4x18	16	70	235	108	125	4x18	16
65	75	250	112	145	4x18	17	75	250	112	145	4x18	17
80	85	250	114	160	4x18	19	85	250	114	160	4x18	19
100	100	260	127	180	8x18	21	100	260	127	180	8x18	21
125	110	280	140	210	8x18	30	110	280	140	210	8x18	30
150	150	310	140	240	8x22	37	150	310	140	240	8x22	37
200	210	380	152	295	8x22	55	210	380	152	295	12x22	55
250	235	395	165	350	12x22	75	235	395	165	355	12x26	75
300	265	425	178	400	12x22	104	265	425	178	410	12x26	104
350	300	480	190	460	16x22	154	300	480	190	470	16x26	158
400	355	535	216	515	16x26	185	355	535	216	525	16x30	185
450	380	570	222	565	20x26	231	380	570	222	585	20x30	241
500	395	590	229	620	20x26	304	395	590	229	650	20x33	304
600	450	675	267	725	20x30	490	450	675	267	770	20x39	492
700	520	770	292	840	24x30	706	520	770	292	840	24x39	706
800	590	840	318	950	24x33	712	590	840	318	950	24x39	712
900	660	915	330	1050	28x33	950	660	915	330	1050	28x39	980
1000	730	1050	410	1160	28x33	1170	730	1050	410	1170	28x45	1300
1200	870	1190	470	1380	32x39	2030	870	1190	470	1390	32x52	2115
1400	1015	1350	530	1590	32x45	2674	1015	1350	530	1590	32x52	2795
1600	1100	1430	600	1820	36x52	3410	1100	1430	600	1820	36x56	3560
1800	1250	1590	670	2020	40x52	4140						
2000	1370	1720	760	2230	44x52	5980						

DN	PN25						PN40					
	Dimensions, mm					Weight with gearbox, kg	Dimensions, mm					Weight with gearbox, kg
	A	B	L	DI	n*d		A	B	L	DI	n*d	
50	70	235	108	125	4x18	17	80	250	150	125	4x18	17
65	75	250	112	145	8x18	18	85	265	170	145	8x18	19
80	85	250	114	160	8x18	20	95	265	180	160	8x18	22
100	100	260	127	190	8x22	25	115	275	190	190	8x22	28
125	110	280	140	220	8x26	32	125	295	200	220	8x26	44
150	150	310	140	250	8x26	42	165	330	210	250	8x26	65
200	210	380	152	310	8x26	67	225	395	230	320	12x30	76
250	235	395	165	370	8x30	82	250	410	250	385	12x33	120
300	265	425	178	430	12x30	139	285	450	270	450	16x33	165
350	300	480	190	490	12x33	172	330	510	290	510	16x33	260
400	355	535	216	550	12x33	229	390	570	310	585	12x39	330
450	380	570	222	600	16x33	312	415	595	330	610	16x39	370
500	395	590	229	660	16x39	380	430	625	350	670	16x45	450
600	450	675	267	770	16x39	571	485	710	390	795	16x52	660
700	520	770	292	875	20x45	808	535	810	430	900	20x52	1096
800	590	840	318	990	20x45	1287	630	890	470	1030	20x56	1500
900	660	915	330	1090	24x52	1520						
1000	730	1050	410	1210	24x56	1860						
1200	870	1190	470	1420	28x56	2510						
1400	1015	1350	530	1640	32x62	3190						

DN	PN63						PN100					
	Dimensions, mm					Weight with gearbox, kg	Dimensions, mm					Weight with gearbox, kg
	A	B	L	DI	n*d		A	B	L	DI	n*d	
50	80	250	150	135	4x22	23						
65	85	265	170	160	8x22	25						
80	95	265	180	170	8x22	27						
100	115	275	190	200	8x26	30	115	275	190	210	8x30	35
125	125	295	200	240	8x30	50	125	295	200	250	8x33	58
150	165	330	210	280	8x33	72	165	330	210	290	12x33	84
200	225	395	230	345	8x33	87	225	395	230	360	8x39	125
250	250	410	250	400	8x39	130	250	410	250	430	8x39	153
300	285	450	270	460	12x39	250	285	450	270	500	12x45	290
350	330	510	290	525	12x39	290	330	510	290	560	12x52	330
400	390	570	310	585	12x45	390	390	570	310	620	12x52	445
500	430	625	350	705	16x52	510						
600	485	710	390	820	16x56	850						

Welded connection

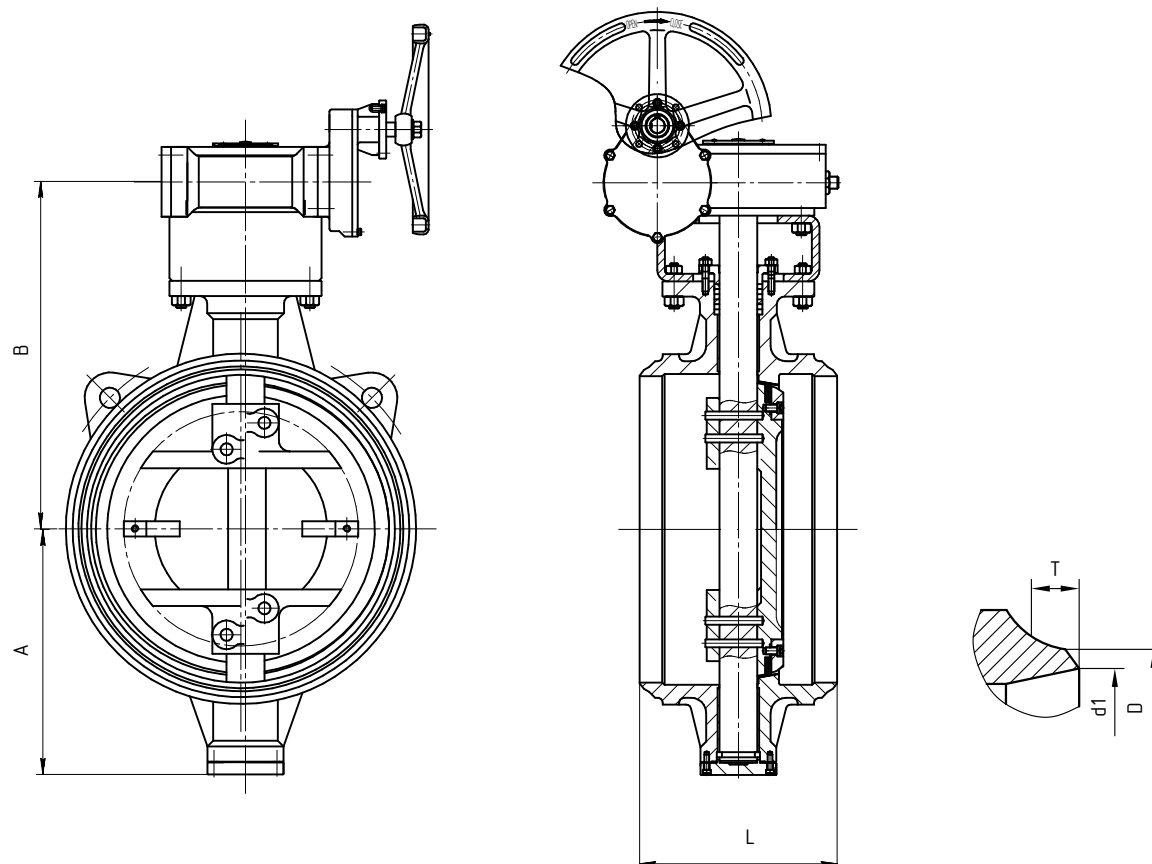

DN	PN6-25							PN40-100						
	Dimensions, mm						Weight with gearbox, kg	Dimensions, mm						Weight with gearbox, kg
	A	B	L	T	d1	D		A	B	L	T	d1	D	
80	98	215	180	6	85	92	30	98	215	180	6	85	92	30
100	112	230	190	6	105	114	37	112	230	190	6	105	114	37
125	125	246	200	6	130	138	44	125	246	200	6	130	138	44
150	155	297	210	6	152	159	51	165	315	210	6	152	159	58
200	200	351	230	9	207	219	62	219	370	230	9	207	219	78
250	231	384	250	9	258	274	84	261	422	250	9	258	274	113
300	261	415	270	9	313	325	115	289	490	270	9	313	325	165
350	298	470	290	9	365	377	153	320	528	290	9	365	377	225
400	331	531	310	9	414	426	187	357	568	310	9	414	426	327
450	369	564	330	9	466	478	292	385	626	330	9	466	480	375
500	404	596	350	9	517	530	324	431	670	350	9	517	530	464
600	473	676	390	9	614	630	436	492	737	390	9	614	630	693
700	538	749	430	14	702	720	668							
800	615	829	470	14	802	820	889,5							
900	628	852	510	14	902	920	1360							
1000	730	1013	550	15	1000	1020	1896							
1200	850	1137	630	15	1200	1220	2615							
1400	980	1348	710	15	1400	1420	3525							
1600	1155	1517	790	18	1600	1620	5496							

Top flange's dimensions and torque for choosing actuator

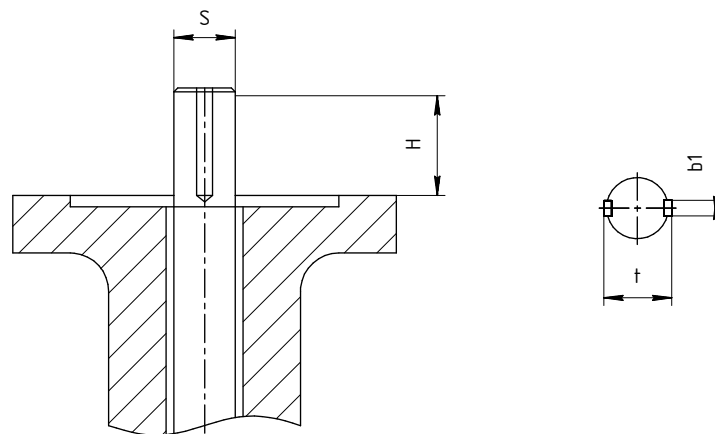

DN	PN10, 16							PN25					PN40						
	Top flange acc. to ISO	Dimensions, mm				Torque, H*m		Top flange acc. to ISO	Dimensions, mm				Torque H*m	Top flange acc. to ISO	Dimensions, mm				Torque H*m
		s	bl	H	t	PN10	PN16		s	bl	H	t			s	bl	H	t	
50	F07	14	6x1	50	16	50	50	F07	14	6x1	50	16	70	F07	14	6x1	50	16	100
80	F07	16	6x1	50	18	65	80	F07	16	6x1	50	18	108	F07	16	6x1	50	18	225
100	F07	18	6x1	50	22	99	125	F07	18	6x1	50	22	171	F07	18	6x1	50	20	315
125	F10	22	8x1	60	24	156	180	F10	22	8x1	60	24	278	F10	26	8x1	60	28	480
150	F10	26	8x1	60	29	239	297	F10	26	8x1	60	29	432	F12	28	10x1	65	31	750
200	F12	28	10x1	65	31	467	585	F12	28	10x1	65	31	752	F12	32	10x1	65	35	1305
250	F12	32	10x1	65	35	753	952	F12	32	10x1	65	35	1242	F14	38	12x1	70	41	2100
300	F14	38	12x1	70	41	1076	1366	F14	38	12x1	70	41	1809	F14	42	12x1	70	45	3045
350	F14	40	12x1	70	43	1479	1895	F14	40	12x1	70	43	2532	F16	45	12x2	90	51	4350
400	F16	45	12x2	90	51	2330	2977	F16	45	12x2	90	51	4355	F16	50	12x2	90	56	7650
450	F16	50	12x2	90	58	2856	3678	F16	50	12x2	90	58	5379	F25	55	16x2	100	63	9300
500	F25	55	16x2	100	63	3708	4764	F25	55	16x2	100	63	7302	F25	65	16x2	100	73	12600
600	F25	65	16x2	100	73	5620	7588	F25	65	16x2	100	73	11216	F25	75	18x2	110	85	19800
700	F25	75	18x2	110	85	7660	10770	F25	75	18x2	110	85	16463	F30	85	22x2	120	95	29700
800	F30	85	22x2	120	97	10695	15100	F30	85	22x2	120	97	23105	F35	95	25x2	140	107	43650
900	F35	95	25x2	140	107	14364	20370	F35	95	25x2	140	107	31220	F35	105	25x2	140	119	58500
1000	F35	105	25x2	140	117	18729	26680	F35	105	25x2	140	117	40940	F40	125	28x2	160	141	76500
1200	F40	125	28x2	160	139	33180	46700	F40	125	28x2	160	139	65730	F48	135	32x2	180	153	125250
1400	F48	145	32x2	180	163	49660	70920	F48	145	32x2	180	163	100830						
1600	F48	165	32x2	190	185	69750	100050												

The data is approximate, for correct selection of electrical and pneumatic actuators it is recommended to consult with the representatives of PromArm company. Stem dimensions and shape are clarified upon request. For DN500 and higher, installation of multiturn actuators through worm gearbox is possible.

Flow capacity of valves K_v , m^3/h

DN	50	65	80	100	125	150	200	250	300	350	400	450
K_v	39	103	150	280	380	750	1390	2400	3780	5590	8000	9620
DN	500	600	700	800	900	1000	1200	1400	1600	1800	2000	
K_v	13780	18910	26960	35210	43250	57240	81480	125631	196432	223785	281540	

Reliability parameters of butterfly valves

DN	40-100	125,150	200-300	350,400	450-600	700-900	1000-2000
Mean life, cycles, not less	5300	4300	3900	3300	2300	1900	1800
Warranty life, cycles, not less than	2000	1700	1600	1400	1000	800	650

Average life and warranty life of the sealing materials identified when testing valves with water according to GOST 2874-82

When operating valves for working mediums other than water, the reliability parameters are determined by the specific mediums, depending on its parameters.

Warranty

The warranty period is 18 months from the date of putting into operation, but not more than 24 months from the date of sale under condition of observance by the consumer of rules of transportation, installation and operation.

Conservation period - 3 years.

Average service life of body parts is not less than 30 years.

Average life removable parts and components – at least 5 years.

Information table for selection of fasteners for disk wafer-type valves with smooth lugs series PA200, PA300, PA600

Mounting of wafer-type valves series PA200, PA300, PA600 is allowed between flat and collar flanges in accordance with GOST 12820-80, GOST 12821-80 with version 1 of sealing surfaces in accordance with GOST 12815-80. Valves of series PA200, PA300 and PA600 are mounted in the pipeline without the use of additional gaskets between the valve body and the mating flanges.

Dimensions and number of studs in accordance with GOST 90BB-75 for one valve*

DN	PN10 kgf/cm ²			PN16 kgf/cm ²		
	Thread size	Length, mm	Qty, pcs.	Thread size	Length, mm	Qty, pcs.
40	M16	110	4	M16	110	4
50	M16	120	4	M16	120	4
65	M16	130	4	M16	130	4
80	M16	130	4	M16	130	4
100	M16	140	8	M16	140	8
125	M16	140	8	M16	150	8
150	M20	150	8	M20	160	8
200	M20	160	8	M20	170	12
250	M20	170	12	M24	190	12
300	M20	180	12	M24	200	12
350	M20	190	16	M24	210	16
400	M24	240	16	M27	240	16
450	M24	260	20	M27	270	20
500	M24	260	20	M30	300	20
600	M27	300	20	M36	340	20
700	M27	340	24			
800	M30	360	24			
900	M30	380	28			
1000	M33	410	24			
1200	M36	470	28			

* Valves DN700 and higher are partially equipped with bolts, because on the body there are blind threaded holes.

Recommendations for the installation of wafer-type valves

The valve design eliminates the need for additional seals between the flanges when mounting on the pipeline. No additional gaskets are allowed.

When mounting, the disk shall be rotated 10-15° from the "closed" position, but the disk must not go beyond the body. Valve mounting in the closed position leads to significant stresses in the seat and an increase in torque to open the valve. This can shorten the valve service life.

For mounting, it is recommended to use mating flanges in accordance with GOST 33259-15, type 11, version B, it is allowed to use flat flanges type 01 acc. GOST 33259-15.

Attention: only **collar flanges** may be used to mount valve with certain diameters - type 11 acc. GOST 33259-15. To clarify the type of mating flanges and select fasteners, we recommend consulting with specialists of PromArm LLC.

It is forbidden to weld flanges to the pipeline when the valve is seated between flanges.

It is necessary to take into account the recommended internal diameter of the pipeline to prevent damage to disk of butterfly valve.

THE LIST OF THE MAIN FACILITIES WHERE BUTTERFLY VALVES MANUFACTURED BY PROMARM WERE SUPPLIED

Company	Address	Company	Address
Industry			
Atmis-Sugar OJSC,	Kamenka http://atmis-sahar.ru	Belinskselemash JSC	Kamenka-6, http://www.bsm.sura.ru
OKBM Afrikantov OJSC	Nizhny Novgorod www.okbm.nnov.ru	Alapaevsky Dairy Plant LLC	Alapaevsk, https://amk-milk.ru
RUSAL Sayanogorsk Aluminum Plant	Sayanogorsk, Khakassia http://www.rusal.ru	NPO Khimsintez JSC	Moscow Region, http://www.himsintez.ru
Kargill LLC	Moscow, http://www.kargill.ru	Perm printing factory - branch of Goznak JSC	Perm, http://ppf.goznak.ru
SUAL JSC, branch UAZ-SUAL	Kamensk-Uralsky, http://www.rusal.ru	Oskol Electrometallurgical Combine JSC	Stary Oskol www.metallinvest.com
Mikhailovsky GOK JSC	Kursk Region, www.metallinvest.com	Stepnogorsk Mining and Chemical Combine LLP	Stepnogorsk
Zangezurysky Copper and Molybdenum Combine JSC	Republic of Armenia, http://www.zcm.am	International Energy Environmental Company LLC	Saint-Petersburg
Polyus PJSC	Moscow, http://polyus.com	Saransk Distillery LLC	Saransk, http://lvz.saransk.ru
Sakhalin Resources LLC	Yuzhno-Sakhalinsk, http://sakhres.com	Electrozinc JSC	Vladikavkaz, http://electrozinc.ugmk.com
Karabashmed' JSC	Karabash http://karmed.rcc-group.ru	YugBunkerServis-Kavkaz LLC	Rostov-on-Don, http://ru.ybunker.com
Uralmash NGO Holding LLC	Tyumen, http://www.uralmash-ngo.com	Energy Alliance - Siberia LLC	Barnaul, http://www.eas-sibir.ru
Mari Pulp and Paper Mill JSC	Volzhsk, http://www.marbum.ru	TD Eniseyprom LLC	Krasnoyarsk, https://eep24.ru/
URALELEKTROMED JSC	Pyshma, http://www.elem.ru	Apatit JSC	Cherepovets, https://www.phosagro.ru
NPO SANEF LLC	Saratov, http://nposanef.ru	TOMET LLC	Samara region, http://tom63.com
Gold of Seligdar JSC	Aldan, http://seligdar.ru	Novotroitsk plant of chromium compounds JSC	Novotroitsk, http://nzhs.ru
Volga JSC	Balakhna, http://www.volga-paper.ru	RusVinyll LLC	Kstovo, https://rusvinyll.ru
Serafimovsky pilot plant of automation and telemechanics LLC	Tuymazinsky district, Serafimovsky, https://www.sozait.ru	KuibyshevAzot PJSC	Togliatti, https://www.kuazot.ru
OK RUSAL Anode Factory LLC	Irkutsk region, Taishet district, the village of Old Akulchet, https://taishetrusal.ru	Uzmetkombinat JSC	Republic of Uzbekistan, Bekabad, http://uzbeksteel.uz
Arkhangelsk Pulp and Paper Mill JSC	Novodvinsk, https://www.appm.ru	Novomoskovsky chlorine LLC	Novomoskovsk
Chelyabinsk Compressor Plant LLC	Chelyabinsk Region, Krasnoarmeysky District https://www.chkz.ru		
Power industry			
Rostov NPP	Rostov Region, Volgodonsk-28	SIBEKO JSC	Novosibirsk, http://www.sibeco.su
Leningrad NPP	Leningrad region, Sosnovy Bor	Kaskad-Hydro LLC	Azerbaijan, Baku
Yakutsk SDPP-2 delivery through UPTK LLC	Republic of Sakha (Yakutia) http://yagres2.ru	Zhanazholskaya GTTPP LPP	Kazakhstan, Aktobe
TPP-Severnaya JSC	Astrakhan, Mosina St, 1	URALTEKHENERGO LLC	Yekaterinburg http://www.ec-ute.ru
Siberian Generation Company LLC	Moscow, http://sibgenco.ru		
Oil and gas industry			
TH KATOIL LLC	Nizhnevarnovsk, http://catoilag.com	Petrol Tekh Snab LLP	Kazakhstan, Uralsk http://petrol-ts.kz
Tamanneftegaz JSC	Krasnodar Territory, http://tamanneftegaz.ru	KATOBNEFT LLC	Nizhnevarnovsk,
KATOIL-Drilling LLC	Buzuluk	Gazpromneft - MNPZ JSC	Moscow, https://mnpz.gazprom-neft.ru
Gazprom Neft Shelf LLC	Saint-Petersburg, https://shelf.gazprom-neft.ru		
Construction			
Kostroma Silicate Plant	Kostroma, http://www.silikatu	Chaadaevsky Plant of Wood Boards LLC	Penza Region, http://dsp.biz/company
Podvodruboprovodstroy JSC	Moscow, http://ptps.ru	Turboenergomont LLC	Saint-Petersburg, www.turboenergo.ru
Centerpromstroy LLP	Republic of Kazakhstan, Temirtau		
Housing and utilities			
Crimean Utility Networks LLC	Krymsk, http://krymsk-seti.ru	Syktyvkar Vodokanal JSC	Syktyvkar, http://svodokanal.ru
Yamal-Kommunenergo JSC	Salekhard, www.yamalkomenergo.ru	ALL-RUSSIAN A.S. PUSHKIN MUSEUM	Saint-Petersburg, www.museumpushkin.ru
MUE Northern Thermal Networks, Municipal Enterprise, SD Vorkuta	Vorkuta	Usinsk Heat Company LLC	Usinsk, http://usinsk-tk.ru

CERTIFICATES

Certificate of conformity



Declaration on conformity with the Technical Regulations of the Customs Union 010/2011 "On safety of machinery and equipment"

Declaration on conformity with the Technical Regulations of the Customs Union 032/2013 "On safety of equipment operating under excessive pressure"



Expert opinion of the Center for Hygiene and Epidemiology

Certificate of fire safety



Certificate of seismic resistance

RMRS Type Approval Certificate



CONTACTS

Company name:	PromArm LLC
Tel / Fax:	+7 (841-2) 35-07-97 (multichannel)
Email:	info@promarm.ru
Legal (mail) address: Working hours:	Baumana St., 101 V, 440052, Penza, Russia 8-00 to 17-00

ПРОМ



PromArm LLC

Address: Baumana St, 101 V,
440052, Penza, Russia

Working hours: 8-00 to 17-00

Tel / Fax: +7 (841-2) 35-07-97
(multichannel)

Email: info@promarm.ru